

Ecology Guideline

For the
ICT Industry
(Version 10) (Draft)



December 16, 2022

ICT Ecology Guideline Council

Ecology Guideline Contents

1.	Background and Purpose	4
1.1	Background	4
1.2	Purpose	5
2.	Definitions	6
2.1	Definitions of Major Guideline Terminologies	6
3.	Relative Positioning and Expected Impact	8
3.1	Scope	8
3.2	Policy	8
3.3	Expectations for Respective Parties	8
3.4	Expected Impact	10
3.5	Revisions	10
3.6	Application of new normative references to equipment	11
3.7	Notice of Disclaimer	11
4.	Outline of the Guideline	12
4.1	Assessment Standards for Equipment Covered	12
4.2	Effort and Assessment Criteria for the “Eco ICT Logo”	31
4.3	Image of Guideline Implementation	32
5.	Assessment Standards	33
5.1	Assessment Standards	33
5.1.1	Scope	33
5.1.2	Stance on Other Assessment Standards	35
5.2	Equipment Definitions, Figure of Merit, Normative References, Measurement Procedures	35
5.2.1	Routers	35
5.2.2	Switching Equipment	40
5.2.3	Transport Equipment	44
5.2.4	PON Equipment	70
5.2.5	Broadband Base Station Equipment	74
5.2.6	Power Supply Equipment	96
5.2.7	Server Equipment	107
5.2.8	Storage Equipment	110
	Reference: Industrial Air-Conditioners	112
5.3	Implementation	114
5.3.1	Addition of new equipment and review of the existing Guideline	114
6.	Assessment Standard for Data Centers	115
6.1	Basic Approach to the Assessment Standard	115
6.2	Definition	115
6.3	Figure of Merit on Energy-Saving as an Assessment Standard	115
6.4	Outline of Figure of Merit on Energy-Saving	117
7.	Assessment Standard for Eco ICT Logo	118
7.1	Purpose	118
7.1.1	Purpose of Self-Assessment of Efforts	119

7.1.2	Indication of Eco ICT Logo	119
7.2	Checklist	119
7.2.1	Purpose of Checklist	119
7.2.2	Checklist Assessment Items and Assessment Standards	119
7.2.3	Review of the Checklist	122
7.3	Eco ICT Logo	122
7.3.1	Method of Indications	122
7.3.2	Usage Stipulations	122
7.4	Implementation	124
7.4.1	Assessment Methods	124
7.4.2	Public Disclosure Methods	124
	Diagram of Logo for Reference	126
Attachment 1	Self-Assessment Checklist for CO ₂ Emission Reduction from Energy Conservation Efforts by Telecommunications Services Providers	127

Revision History

Initial version: Version 1, February 1, 2010

Revised: Version 1.1, December 27, 2010

Revised: Version 2, March 9, 2011

Revised: Version 3, December 27, 2011

Revised: Version 4, February 6, 2013

Revised: Version 5, February 6, 2014

Revised: Version 6, February 3, 2015

Revised: Version 7, February 5, 2016

Revised: Version 7.1, February 1, 2017

Revised: Version 8, February 1, 2018

Revised: Version 8.1, January 23, 2019

Revised: Version 8.2, February 13, 2020

Revised: Version 9, March 4, 2021

Revised: Version 10, February xx, 2023

Registered trademark, trademark

Enterprise names and product names mentioned in this Guideline may be registered trademarks or used as trademarks as well.

Contacts

Telecommunications Carriers Association

e-mail: enq<AT>tca.or.jp

Telecom Services Association

e-mail: jimukyoku<AT>telesa.or.jp

Japan Internet Providers Association

e-mail: info<AT>jaipa.or.jp

Communications and Information network Association of Japan

e-mail: ecoc<AT>ciaj.or.jp

Japan Cloud Industry Association

e-mail: office<AT>aspicjapan.org

1. Background and Purpose

1.1 Background

In the face of global warming, Japan must take responsible action to reduce CO₂ emissions and the info-communications technology (ICT) industry needs to further strengthen its own voluntary efforts currently in effect.

As mentioned in the April 2008 Report Released by the “Study Group on ICT Policy for Addressing Global Warming (Ministry of Internal Affairs and Communications: MIC),” the use of ICT can dramatically increase efficiency in production, consumption and industrial activities and greatly contribute to the reduction of carbon emissions by replacing physical travel and easing traffic congestion. However, the growth in the scale of ICT services which are realized through configuring network equipment, servers, and other devices, and the resulting traffic volume have led to increased consumption of energy (electricity), translating into escalating CO₂ emissions.

To address this increase in CO₂ emissions, the MIC report released in June 2009 by its “Study Group on Ecological Measures in the Info-communications Industry” listed (i) the procurement of energy-efficient equipment by telecommunications services providers and (ii) making reductions in CO₂ emissions through energy conservation by telecommunications services providers more visible - as two of the numerous effective measures in decreasing CO₂ emissions. It also sought the creation of a guideline by ICT associations with the cooperation of equipment vendors and other relevant entities, covering such topics as “assessment of CO₂ emissions by equipment,” “labeling” and “Eco ICT Logo.”

With the release of this MIC report, the five industry organizations: Telecommunications Carriers Association (TCA), Telecom Services Association (TELESA), Japan Internet Providers Association (JAIPA), Communications and Information network Association of Japan (CIAJ) and ASP-SaaS-Cloud Consortium (ASPIC) created the “ICT Ecology Guideline Council,” (hereafter referred to as “Council”) on June 26, 2009 to contribute to decreasing CO₂ emissions through the cooperative efforts to lower energy-consumption among ICT equipment users - including telecommunications services providers - and manufacturers. The mission of the Council is to (1) determine an “assessment standard” for use in energy-efficient “procurement standards” of equipment and data center services by telecommunications services providers and (2) create a guideline for “establishing procurement standards” and a “self-assessment of actions” to indicate appropriate CO₂ reduction measures through energy conservation taken by individual telecommunications services providers.

1.2 Purpose

Curbing power consumption by the equipment used to provide services is an effective way for telecommunications services providers to reduce CO₂ emissions through energy conservation. To that end, it is appropriate for individual telecommunications services providers to establish “procurement standards” for buying telecommunications equipment and services that emit lower amounts of CO₂.

Furthermore, telecommunications services providers need to endeavor to increase energy efficiency across the entire business spectrum. To further promote ecology-conscious actions by telecommunications services providers, individual companies need clear normative actions, and there needs to be a framework that simplifies assessment by a third-party.

In consideration of these factors, this Guideline sets forth points 1) and 2) below and by doing so, seeks to enhance ecology-conscious actions, such as efforts to reduce CO₂ emissions through energy conservation by telecommunications services providers. This Guideline also aims to promote ecology-consciousness among non-telecommunications services providers who use ICT equipment.

(1) Guideline to establish procurement standards of energy-saving equipment

Indicate an “assessment standard” to assist the formulation of “procurement standards” by telecommunications services providers for equipment and services with a focus on the reduction of CO₂ emissions through energy conservation.

(2) Guideline for disclosing self-assessment of ecology-conscious actions

Prepare a framework for public disclosure that facilitates an understanding of the status of efforts to reduce CO₂ emissions through energy conservation, in order to show that telecommunications services providers are appropriately making such efforts. To that end, the Council will provide a Self-Assessment Checklist and “Eco ICT Logo.”

Furthermore, this guideline is a reference for telecommunications services providers in establishing voluntary procurement standards. It is possible that equipment deemed necessary by telecommunications services providers due to performance and functional requirements do not meet the energy-saving standards of this guideline.

2. Definitions

2.1 Definitions of Major Guideline Terminologies

(1) Telecommunications services providers

Under this Guideline, an entity providing telecommunication services based on the Telecommunications Business Act is referred to as a telecommunications services provider. Moreover, the term is not limited to entities belonging to an industry organization.

(2) Vendor

Under this Guideline, “vendors” refer to all equipment manufacturers (including OEM businesses) but does not include businesses dealing solely in sales and distribution.

(3) Eco ICT Logo

A symbol for broadly disseminating to the public that self-assessment of CO₂ emission reduction through energy conservation and other ecologically conscious activities are being performed.

(4) Figure of merit

An index used to calculate the energy-saving effects of a device or data center.

(5) Assessment result

A result of assessment based on actual measurement.

(6) Normative reference

An assessment standard (expressed as an assessment scale) for determining the energy-saving effect.

(7) Assessment scale

An assessment scale of five ranks representing rate of reduction in energy consumption vs. the normative reference shall be used to facilitate the understanding of the energy efficiency of devices or data centers. Ranks are indicated by the number of stars (★). The greater the number of stars, the greater the energy efficiency.

(8) Self-assessment checklist

A table of assessment items established by the Council to be used for self-assessment and public disclosure of ecology-conscious actions.

(9) Assessment standard based on the Top Runner Program

Target reference values for energy conservation set forth under the Act on the Rational Use of Energy (hereinafter referred as the Energy Conservation Law), which

promotes equipment manufacturers and other relevant entities to manufacture energy-efficient products by setting normative references to be achieved.

3. Relative Positioning and Expected Impact

3.1 Scope

This guideline basically applies to telecommunications services providers but also considers serving as a reference for companies outside the scope of telecommunications services providers that are planning “procurement standards” or are engaged in broader efforts to reduce CO₂ emissions.

The “Eco ICT Logo” shall be used not only by a person who operates a telecommunications business defined under the Telecommunications Business Act, but may be used by a person who operates a business related to telecommunications services using substantial ICT equipment.

3.2 Policy

As stated in 1.2 Purpose, the policy of this Guideline is to (1) lay down guidelines for establishing a procurement standard of energy-saving equipment among telecommunications services providers and (2) lay down guidelines for self-assessment and disclosing ecology-conscious actions.

As for (1), laying down guidelines for establishing procurement standards of energy-saving equipment among telecommunication carriers, this Guideline sets forth:

- categories, relevant equipment and assessment standards that can be shared amongst the vendors and companies making the procurement; and
- directions for easy-to-understand notations to be used by those involved in procurement.

As for (2), laying guidelines for self-assessment and disclosing ecology-conscious actions, this Guideline proposes:

- a method of public disclosure using self-assessment checklists and “Eco ICT Logo.”

3.3 Expectations for Respective Parties

By creating this Guideline, we expect the respective parties to take the following actions:

(1) Telecommunications services providers

[1] Establishment of Procurement Standards

Referring to the figure of merit and assessment standards provided in this Guideline for equipment and data centers, telecommunications services providers shall formulate their own procurement standards while allowing for safety and reliability considerations. Specifically, in procuring equipment before the “approximate date for achieving normative reference,” the product with the highest energy efficiency among 1 ★ to 5 ★ products, and if after the

“approximate date for achieving normative reference,” the product with the highest energy efficiency among 2★ to 5★ products shall be the target. Furthermore, since the process for establishing normative references and their approximate date of achievement vary by equipment, it is necessary to note that comparing the energy efficiency by looking at the number of ★ in the assessment scale among different equipment may not be appropriate. See the example images below for reference.

Example of establishing a uniform procurement standard for equipment and/or services.

<Image for use as reference>

Company ABC's Procurement Standard (executed in FYxx)

In procuring materials, we at our company have clearly defined our stance to contribute to the creation of a sound material-cycle society and have established a procurement standard to further promote this effort.

1. Scope of equipment covered: ICT equipment and services
2. Procurement standard

For equipment listed in the “Ecology Guideline for ICT Industry,” procurement decisions shall basically be made from among equipment with energy-saving ranking of n stars or above.

For equipment not listed in the Guideline, the equipment with the lowest possible electric power consumption shall be procured.

Example of establishing a procurement standard per equipment

<Image for use as reference>

Company ABC's Procurement Standard (executed in FYxx)

In procuring materials, we at our company have clearly defined our stance to contribute to the creation of a sound material-cycle society and have established a procurement standard to further promote this effort.

Scope of equipment covered, procurement standard

For the following equipment listed in the “Ecology Guideline for ICT Industry,” procurement decisions shall basically be made from among equipment with energy-saving ranking stars [★] or above listed to the right of the Equipment Type below. For equipment not listed in the Guideline, the equipment with the lowest possible electric power consumption shall be procured.

Equipment A: n stars or above

Equipment B: n stars or above

[2] Indication of the “Eco ICT Logo”

Check the status of efforts and achievements in reducing CO₂ emissions through energy conservation and disclose those results using an “Eco ICT Logo,” to show that telecommunications services providers are appropriately engaged in efforts to reduce CO₂ emissions.

(2) Vendors

[1] Indication of equipment assessment outcome

Vendors must measure and evaluate energy-saving equipment covered by the scope of this Guideline in accordance to section 5.2 of this Guideline and publicly disclose the assessment outcome (assessment results and assessment scale ranking).

(3) Data center operators

[1] Public disclosure of data

In relation to data center services, data center operators shall publicly disclose energy-saving measures which would serve as a reference for procurement by telecommunications services providers.

3.4 Expected Impact

The relevant equipment and assessment standards indicated in this Guideline allow for the establishment of categories and assessment standards that can be shared by both vendors and the companies making the procurement, which benefits both sides to the extent it can eliminate inconsistencies in manufacturing and procurement. Furthermore, it is expected that as telecommunications services providers add energy-saving items to their procurement standards and actively install energy efficient equipment, this, in turn, will promote the development of energy efficient ICT equipment.

By formulating an assessment standard with the objective of saving energy, it is hoped that standardization bodies will accelerate deliberations of low power-consuming technologies (such as technologies to control stand-by power of access equipment).

3.5 Revisions

This guideline will require appropriate response to: changes in policy relating to global warming measures; the status of ICT service provision; penetration of equipment and the like; and technological advances. To that end, even after its establishment, this Guideline shall continue to be studied by the Council and:

- the scope of equipment covered shall be broadened, and
- review of the criteria, such as figure of merit and normative reference shall be made.

3.6 Application of new normative references to equipment

The new normative reference shall apply to equipment where development started after announcement of the new specifications, whereas the old normative reference shall apply to any equipment developed and sold (existing equipment) prior to the announcement.

3.7 Notice of Disclaimer

This Guideline shall be used as reference by telecommunications services providers at their own discretion to determine standards for procuring ICT equipment or data centers. As for the “Eco ICT Logo,” the telecommunications services provider shall be responsible for filling out the check list, making the information public and using the logo.

The Council shall not be liable for any damages and/or conflicts resulting from the use of this Guideline. It is presumed that the user of this Guideline shall be responsible for any incidental or consequential damages and/or conflicts resulting from the use of this Guideline.

4. Outline of the Guideline

4.1 "Assessment standards" for equipment covered (for details, see 5.2)

(1) Equipment covered in this Guideline and relevant values

* An assessment scale is designated for each Equipment Type based on normative references (refer to the following table and/or section 5.2).

Equipment Type	Category	Equipment name	Figure of merit	Normative reference	Approximate date for achieving normative reference	Notes
Broadband router ¹ (no VPN function)	A	Wired router	Power consumption (W) ⁸	4	End of FY2010	X2: 2.4 GHz wireless output (mW/MHz) X5: 5 GHz wireless output (mW/MHz) *Figure of merit and normative reference shall be compliant with top runner assessment standards.
	B	VoIP Wired router		5.5		
	C	Wireless router (2.4 GHz)		$0.10 \times X2 + 3.9$		
		Wireless router (5 GHz)		$0.15 \times X5 + 3.9$		
		Wireless router (2.4 GHz + 5 GHz)		$0.10 \times X2 + 0.15 \times X5 + 5.1$		
	D	ADSL router		7.4		
	E	ADSL router with VoIP		7.4		
F	wireless ADSL router	8.8				

Layer-2 switch (box type) ²	A	Layer-2 switch (with SNMP management and IP filtering functions)	Power consumption (W)/ maximum effective transmission rate (Gbps) ⁹	$(\alpha_n + P_n) / T$	End of FY2011	α_n : sum of power consumption of port and fixed power consumption P_n : additional power consumption of PoE T : maximum effective transmission rate n : Category (A, B, C, D) *Figure of merit and normative reference shall be compliant with top runner assessment standards.
	B	Layer-2 switch (with SNMP management function, w/o IP filtering function)				
	C	Layer-2 switch (with Web management function)				
	D	Layer-2 switch (w/o management function)				
Transport equipment ³	WDM	DWDM device (10 Gbps)	Maximum throughput (Gbps)/avg power consumption (W) ¹⁰	0.33	End of FY2016 ²⁵	Average power consumption = (power consumption at full wavelength + power consumption at +1 wavelength) / 2
		DWDM device (40 Gbps)		0.40		
		DWDM device (100 Gbps)		0.86		
		DWDM device (200 Gbps)		1.79	End of FY2019 ²⁸	
		DWDM device (400 Gbps)		3.15	End of FY2022	

		CWDM device (10 Gbps)		0.57	End of FY2016 ²⁵	
	Converged packet optical equipment	Converged packet optical equipment (packet & TDM functions)	Maximum throughput (Gpbs)/ average power consumption ¹¹	0.1009(10Gbps) 0.2065(100Gbps)	End of FY2014 ²³	Maximum throughput = $\sqrt{(A^2+B^2)}/2$ A: maximum throughput of the packet functional part (Gbps) B: maximum throughput of the TDM functional part (Gbps) Average power consumption = $(P_{idle} + P_{max})/2$ P_{idle} : Power consumption (W) of total equipment with no data throughput with minimum components and path configuration P_{max} : Power consumption (W) of total equipment during main signal transmission with maximum component configuration
		Converged packet optical equipment (packet & WDM functions) (when WDM function part is 100G x N)		0.1880	End of FY2016 ²⁵	Maximum throughput = $\sqrt{[A^2 + (C \times \alpha)^2]}/2$ A: maximum throughput of the packet functional part (Gbps) C: maximum throughput of the WDM functional part (Gbps) α : Add/Drop rate of WDM part Average power consumption = $(P_{idle} + P_{max})/2$ P_{idle} : Power consumption (W) of total equipment with no data throughput with minimum

						components and path configuration P _{max} : Power consumption (W) of total equipment during main signal transmission with maximum component configuration
PON equipment (OLT) ⁴	GE-PON	OLT (AC power source)	Average power consumption(W)/total number of lines ¹²	0.40	End of FY2016 ²⁵	Average power consumption = (P100 + P50 + P0) / 3 Total number of lines = total number of IF ports X no. of PON branches
		OLT (DC power source)		0.34		
		ONU (100Mbps)	Average power consumption (W) ¹³	2.84	End of FY2016 ²⁵	Average power consumption = (P100 + P50 + P0) / 3
		ONU (1Gbps)		3.75		
Broadband base station equipment ⁵	WiMAX	WiMAX base station (integrated 10W device (1 system))	$\sum P_n / \{P_{idle} \times (1 - \alpha) + P_{max} \times \alpha\}$ ¹⁴	12.60	End of FY2012 ²¹	P _n : power transmission by antenna terminal n (W) P _{idle} : primary supply-side power when there is no load (W) P _{max} : primary supply-side power at maximum transmission (W) α : average daily down link transmission traffic rate.
		WiMAX base station (integrated 10W device (2 systems))		9.63		
		WiMAX base station (integrated 5W device (1 system))		5.84		

	LTE	LTE base stations (segregated 20W device)		20.32	End of FY2013 ²²	
		LTE base stations (integrated 20W device)		13.77		
		LTE base stations (segregated 10W device)		6.91		
	3G/LTE	3G/LTE Multi-Radio Base Stations (segregated 10W device)	$\frac{\sum (P_{3Gout} + P_{LTEout})}{\{(P_{idle} + P_{max}) / 2\}^{14}}$	5.90	End of FY2015 ²⁴	<p>[Transmission power of 3G 2 antennas base station equipment] $P_{3Gout}: P_{3Gout1} + P_{3Gout2}$ P_{3Gout1}: Transmission power (W) from antenna connector 1 P_{3Gout2}: Transmission power (W) from antenna connector 2</p> <p>[Transmission power of LTE 2 antennas base station equipment] $P_{LTEout}: P_{LTEout1} + P_{LTEout2}$ $P_{LTEout1}$: Transmission power (W) from antenna connector 1 $P_{LTEout2}$: Transmission power (W) from antenna connector 2</p> <p>P_{idle}: Primary supply-side input power (W) when there is no load P_{max}: Primary supply-side input power (W) during maximum transmission T_i: Maximum throughput per 1CA cell (i) in P_{max} state (Mbps) α: average daily down link transmission traffic</p>
	LTE-Advanced	LTE-Advanced base stations (segregated 10W device)	$\frac{\sum T_i}{\{P_{idle} \times (1 - \alpha) + P_{max} \times \alpha\}}$	0.4542	End of FY2018 ²⁷	
	<u>5G</u>	<u>5G base stations (20W×4 device)</u>		<u><reference> 3.1803</u>		
Power supply equipment ⁶	External power source	AC adapter	Average conversion efficiency ¹⁵	<Standard voltage (6V and above)> $0.071 \ln(P_{no}) + 0.0014 \ln(P_{no})$	End of FY2019 ²⁸	<p>Average conversion efficiency = $(\eta_{25} + \eta_{50} + \eta_{75} + \eta_{100}) / 4$ η_n: efficiency at n%load P_{no}: nameplate output</p>

				<Low voltage (less than 6V)> $0.00834\ln(P_{no})+0.0014\ln(P_{no})$		(W) * Figure of merit shall be compliant with U.S. Federal mandatory standard (Energy Conservation Standard released by the U.S. Department of Energy).
Rectifier	Single-phase AC100V input, 48V output rectifier	Average conversion efficiency x 1,000 ¹⁶	872	End of FY2017 ²⁶	Average conversion efficiency = $(\eta_{30} + \eta_{40} + \eta_{50} + \eta_{60} + \eta_{70} + \eta_{80})/6$ η_n : efficiency at n%load * Figure of merit shall be compliant with ATIS specs	
	Single-phase AC200V input, 48V output rectifier		878			
	3-phase AC200/400 V input, 48V output rectifier (output power<5k W)		891			
	3-phase AC200/400 V input, 48V output rectifier (output power \geq 5k W)		908			
	3-phase AC200/400 V input, 380V output rectifier		944	End of FY2017 ²⁶		
UPS	3-phase 200V with trans, 200 kVA or above and less than 500 kVA.	Average conversion efficiency ¹⁷	89.2	End of FY2018 ²⁷	Average conversion efficiency = $(\eta_{25} + \eta_{50} + \eta_{75} + \eta_{100})/4$ η_n : efficiency at n%load	

		3-phase 200V with trans, 500 kVA or above.		89.9		
		3-phase 415V with trans, 500 kVA or above.		90.9		
		3-phase 200V transless, 200 kVA or above and less than 500 kVA.		92.7		
		3-phase 415V transless, 200 kVA or above and less than 500 kVA.		95.5		
		3-phase 415V transless, 500 kVA or above.		96.2		
Server_ equipment 7	1	x86 (Number of CPU sockets=1)	exp ($0.65 \times \ln$ (Eff_{CPU}) + $0.3 \times \ln$ ($\text{Eff}_{\text{Memory}}$) + $0.05 \times \ln$ ($\text{Eff}_{\text{storage}}$)) 18	8.9	End of FY2021	Eff _{CPU} : energy efficiency ratio of CPU workload Eff _{Memory} : energy efficiency ratio of memory workload Eff _{storage} : energy efficiency ratio of strage workload *Figure of merit shall be compliant with SERT Ver.2.0 specs and normative reference shall be compliant with top runner assessment standards.
	2	x86 (Number of CPU sockets=2)		11.9		
	3	x86 (Number of CPU sockets=4)		8.9		
	4	SPARC (Number of CPU sockets=1)		6.3		
	5	SPARC (Number of CPU sockets=2)		4.2		

	6	SPARC (Number of CPU sockets=4)		3.5		
	7	Power (Number of CPU sockets=1)		4.6		
	8	Power (Number of CPU sockets=2)		4.9		
	9	Power (Number of CPU sockets=4)		4.2		
Storage equipment (subsystems) ¹⁹	<u>IV</u>	<u>Number of disk drives=between 2 and 11</u>	<u>Power consumption (W)/Storage capacity (GB)²⁰</u>	<u>E=exp (1.56 x In (N) - 17.7)</u>	<u>End of FY2023</u>	N: no. of steady revolutions (unit: revolutions per minute) *Figure of merit and normative reference shall be compliant with top runner assessment standards.
	<u>V</u>	<u>Number of disk drives=12 or more, including the 3.5-inch disk drive</u>		<u>0.0017</u>		
	<u>VI</u>	<u>Number of disk drives=12 or more, only the 2.5-inch disk drive</u>		<u>E=exp (0.952 x In (N) - 14.2)</u>		

¹ Broadband router

Routers which relay data using International Organization for Standardization (ISO) OSI (Open System Interconnection) layer 3 (network layer) using IP addresses included in the destination information of packets, and with an effective transmission rate of no more than 200 Mbps (no more than 100 Mbps for wireless routers).

² Layer 2 (L2) switch

Equipment which relays data on the network using International Organization for Standardization (ISO) OSI (Open System Interconnection) layer 2 (data link layer).

³ Transport equipment

Equipment whose main task is to relay data on the network using International Organization for Standardization (ISO) OSI (Open System Interconnection) layer 1 (physical layer). This category includes WDM equipment, electric multiplexers and FC switches.

⁴ PON equipment

A name for a category of optical access devices for building PON (Passive Optical Network) systems, including GE-PON, G-PON and 10GE-PON equipment

⁵ Broadband base station equipment

A generic term for a category of radio base station equipment such as WiMAX base station or LTE base station equipment.

⁶ Power supply equipment

A device which provides electric power to the equipment and is physically separate and independent of the equipment.

⁷ Server

A computer device comprising of a central processing unit (CPU), a main memory, an input/output control and a power source. It exists as part of a network to provide information and services to other computer devices. It is designed to use an operating system (OS) so that it can be installed with and run user applications.

⁸ The power consumed at maximum effective transmission rate. The smaller the number, the greater the energy efficiency.

⁹ The power consumed at maximum effective transmission rate. The smaller the number, the greater the energy efficiency.

¹⁰ Maximum throughput at average power consumption (average power consumption of full wave length and 1 wave length). The greater the number, the greater the energy efficiency.

¹¹ Maximum throughput per average power consumption (average power consumption at loads of 100% and 0%). The greater the number, the greater the energy efficiency.

¹² Average power consumption (average power consumption at loads of 100%, 50% and 0%) per line. The smaller the number, the greater the energy efficiency.

¹³ Average power consumption (average power consumption at loads of 100%, 50% and 0%). The smaller the number, the greater the energy efficiency.

¹⁴ Transmission power (total per antenna) at average input power (average input power at loads of 100% and 0% when applying daily traffic rates). The greater the number, the greater the energy efficiency.

¹⁵ Average conversion efficiency at loads of 100%, 75%, 50% and 25%. The greater the number, the greater the energy efficiency.

¹⁶ Average conversion efficiency at loads of 80%, 70%, 60%, 50%, 40% and 30%. The greater the number, the greater the energy efficiency.

¹⁷ Average conversion efficiency at loads of 100%, 75%, 50% and 25%. The greater the number, the greater the energy efficiency.

¹⁸ The weighted geometric mean of the workloads calculated in workload energy efficiency, with each component of a server computer (CPU, memory, and storage). The greater the number, the greater the energy efficiency.

¹⁹ A subsystem refers to 1 unit containing multiple disk drives, magnetic disk control unit, and magnetic disk device (for machines using only the magnetic disk control unit within the computer, 1 unit refers to a chassis with an assigned model number/name).

²⁰ Power consumption per 1GB. The smaller the number, the greater the energy efficiency.

²¹ Reviewing of the reference value had been done in FY2013. Taking market and technological trend into consideration, we decided to keep normative reference value as it is.

²² Reviewing of the reference value had been done in FY2014. Taking market and technological trend into consideration, we decided to keep normative reference value as it is.

²³ Reviewing of the reference value had been done in FY2015. Taking market and technological trend into consideration, we decided to keep normative reference value as it is.

²⁴ Reviewing of the reference value had been done in FY2016. Taking market and technological trend into consideration, we decided to keep normative reference value as it is.

²⁵ Reviewing of the reference value had been done in FY2017. Taking market and technological trend into consideration, we decided to keep normative reference value as it is.

²⁶ Reviewing of the reference value had been done in FY2018. Taking market and technological trend into consideration, we decided to keep normative reference value as it is.

²⁷ Reviewing of the reference value had been done in FY2019. Taking market and technological trend into consideration, we decided to keep normative reference value as it is.

²⁸ Reviewing of the reference value had been done in FY2020. Taking market and technological trend into consideration, we decided to keep normative reference value as it is.

(2) Assessment scale for relevant equipment

[1] Broadband router (no VPN function)

Figure of merit: Energy efficiency ratio E_n =power consumption (W)

NR=normative reference

Assessment scale	Rate of reduction vs. power consumption at NR	Energy efficiency ratio per category E_n (W)						Notes
		A	B	C	D	E	F	
★★★★★	$n \geq 30\%$	$E_n \leq E \times 0.7$						Normative reference E (W) per table under 5.2.1.1 (3) Normative References
★★★★	$20\% \leq n < 30\%$	$E \times 0.7 < E_n \leq E \times 0.8$						
★★★	$10\% \leq n < 20\%$	$E \times 0.8 < E_n \leq E \times 0.9$						
★★ (includes NR)	$0\% \leq n < 10\%$	$E \times 0.9 < E_n \leq E$						
★	(Normative reference not achieved)	$E_n > E$						

[2] Layer-2 switch (box type)

Figure of merit: Energy efficiency ratio E_n =energy consumption (W)/ maximum effective transmission rate (Gbps)

NR=normative reference

Assessment scale	Rate of reduction vs. power consumption at NR	Energy efficiency ratio per category E_n (W)				Notes
		A	B	C	D	
★★★★★	$n \geq 30\%$	$E_n \leq E \times 0.7$				Normative Reference E (W/Gbps) per table under 5.2.2.1 (3) Normative References
★★★★	$20\% \leq n < 30\%$	$E \times 0.7 < E_n \leq E \times 0.8$				
★★★	$10\% \leq n < 20\%$	$E \times 0.8 < E_n \leq E \times 0.9$				
★★ (includes NR)	$0\% \leq n < 10\%$	$E \times 0.9 < E_n \leq E$				
★	(Normative reference not achieved)	$E_n > E$				

Note: Rate of reduction of power consumption vs. NR shall be comparable for equipment with similar maximum effective transmission rates.

[3] WDM

Figure of merit: TEER= maximum throughput (Gbps)/ average power consumption (W)

NR=normative reference

Assessment scale	Rate of reduction vs. power consumption at NR	Average power consumption for 800 Gbps DWDM(10 Gbps)	Average power consumption for 3,200 Gbps DWDM(40 Gbps)

★★★★★	$n \geq 30\%$	$P \leq 1,696.96$	$P \leq 5,600.00$
★★★★	$20\% \leq n < 30\%$	$1,696.96 < P \leq 1,939.39$	$5,600.00 < P \leq 6,400.00$
★★★	$10\% \leq n < 20\%$	$1,939.39 < P \leq 2,181.81$	$6,400.00 < P \leq 7,200.00$
★★ (includes NR)	$0\% \leq n < 10\%$	$2,181.81 < P \leq 2,424.24$	$7,200.00 < P \leq 8,000.00$
★	(Normative reference not achieved)	$P > 2,424.24$	$P > 8,000.00$

Note: TEER (Telecommunications Energy Efficiency Ratio)

Assessment scale	Rate of reduction vs. power consumption at NR	Average power consumption for 8,000 Gbps DWDM(100 Gbps)	Average power consumption for 16,000 Gbps DWDM(200 Gbps)
★★★★★	$n \geq 30\%$	$P \leq 6,511.62$	$P \leq 6,256.97$
★★★★	$20\% \leq n < 30\%$	$6,511.62 < P \leq 7,441.85$	$6,256.97 < P \leq 7,150.83$
★★★	$10\% \leq n < 20\%$	$7,441.85 < P \leq 8,372.08$	$7,150.83 < P \leq 8,044.68$
★★ (includes NR)	$0\% \leq n < 10\%$	$8,372.08 < P \leq 9,302.32$	$8,044.68 < P \leq 8,938.54$
★	(Normative reference not achieved)	$P > 9,302.32$	$P > 8,938.54$

Note: TEER (Telecommunications Energy Efficiency Ratio)

Assessment scale	Rate of reduction vs. power consumption at NR	Average power consumption for 32,000 Gbps DWDM(400 Gbps)	Average power consumption for 40 Gbps CWDM(10 Gbps)
★★★★★	$n \geq 30\%$	$P \leq 7,111.11$	$P \leq 49.11$
★★★★	$20\% \leq n < 30\%$	$7,111.11 < P \leq 8,126.98$	$49.11 < P \leq 56.13$
★★★	$10\% \leq n < 20\%$	$8,126.98 < P \leq 9,142.85$	$56.13 < P \leq 63.15$
★★ (includes NR)	$0\% \leq n < 10\%$	$9,142.85 < P \leq 10,158.73$	$63.15 < P \leq 70.17$
★	(Normative reference not achieved)	$P > 10,158.73$	$P > 70.17$

Note: TEER (Telecommunications Energy Efficiency Ratio)

[4] Converged Packet Optical Equipment

Figure of merit: $E = \text{Maximum throughput (Gpbs)}/\text{average power consumption (W)}$

Assessment scale	Rate of reduction vs. power consumption at NR	Average power consumption (W) with 50Gbps packet function and 50Gbps TDM function
★★★★★	$n \geq 30\%$	$P \leq 346.87$
★★★★	$20\% \leq n < 30\%$	$346.87 < P \leq 396.43$
★★★	$10\% \leq n < 20\%$	$396.43 < P \leq 445.98$

★★ (includes NR)	$0\% \leq n < 10\%$	$445.98 < P \leq 495.54$
★	Normative reference not achieved	$P > 495.54$

Assessment scale	Rate of reduction vs. power consumption at NR	Average power consumption (W) with 1,600Gbps packet function and 1,600Gbps TDM function
★★★★★	$n \geq 30\%$	$P \leq 5,423.72$
★★★★	$20\% \leq n < 30\%$	$5,423.72 < P \leq 6,198.54$
★★★	$10\% \leq n < 20\%$	$6,198.54 < P \leq 6,973.36$
★★ (includes NR)	$0\% \leq n < 10\%$	$6,973.36 < P \leq 7,748.18$
★	Normative reference not achieved	$P > 7,748.18$

Assessment scale	Rate of reduction vs. power consumption at NR	Average power consumption (W) with 8,000 Gbps packet function and 8,000 Gbps WDM function
★★★★★	$n \geq 30\%$	$P \leq 29,787.23$
★★★★	$20\% \leq n < 30\%$	$29,787.23 < P \leq 34,042.55$
★★★	$10\% \leq n < 20\%$	$34,042.55 < P \leq 38,297.87$
★★ (includes NR)	$0\% \leq n < 10\%$	$38,297.87 < P \leq 42,553.19$
★	Normative reference not achieved	$P > 42,553.19$

[5] GE-PON

OLT figure of merit: E= average energy consumption (W)/ total no. of lines

ONU figure of merit: P= average energy consumption (W)

NR=normative reference

Assessment scale	Rate of reduction vs. power consumption at NR	Average power consumption for OLT (AC power source) (W)	Average power consumption for OLT (DC power source) (W)
★★★★★	$n \geq 30\%$	$E \leq 0.280$	$E \leq 0.238$
★★★★	$20\% \leq n < 30\%$	$0.280 < E \leq 0.320$	$0.238 < E \leq 0.272$
★★★	$10\% \leq n < 20\%$	$0.320 < E \leq 0.360$	$0.272 < E \leq 0.306$
★★ (includes NR)	$0\% \leq n < 10\%$	$0.360 < E \leq 0.400$	$0.306 < E \leq 0.340$
★	(Normative reference not achieved)	$E > 0.400$	$E > 0.340$

Assessment scale	Rate of reduction vs. power consumption at NR	Average power consumption for ONU (100 Mbps)	Average power consumption for ONU (1 Gbps)
★★★★★	$n \geq 30\%$	$P \leq 1.988$	$P \leq 2.625$
★★★★	$20\% \leq n < 30\%$	$1.988 < P \leq 2.272$	$2.625 < P \leq 3.000$

★★★	$10\% \leq n < 20\%$	$2.272 < P \leq 2.556$	$3.000 < P \leq 3.375$
★★ (includes NR)	$0\% \leq n < 10\%$	$2.556 < P \leq 2.840$	$3.375 < P \leq 3.750$
★	(Normative reference not achieved)	$P > 2.840$	$P > 3.750$

[6] WiMAX base station equipment

Figure of merit: $E = \text{total transmission power (W)} / \text{average primary input power (W)}$

Assessment scale	Rate of reduction vs. power consumption at NR	Reference average power consumption (W) for integrated 10W equipment (single) (Note 1)	Reference average power consumption (W) for integrated 10W equipment (dual) (Note 1)
★★★★★	$n \geq 30\%$	$P \leq 111.09$	$P \leq 145.39$
★★★★	$20\% \leq n < 30\%$	$111.09 < P \leq 126.96$	$145.39 < P \leq 166.16$
★★★	$10\% \leq n < 20\%$	$126.96 < P \leq 142.83$	$166.16 < P \leq 186.93$
★★ (includes NR)	$0\% \leq n < 10\%$	$142.83 < P \leq 158.70$	$186.93 < P \leq 207.70$
★	(Normative reference not achieved)	$P > 158.70$	$P > 207.70$

Assessment scale	Rate of reduction vs. power consumption at NR	Reference average power consumption (W) for integrated 5W equipment (single) (W) (Note 2)	
★★★★★	$n \geq 30\%$	$P \leq 119.86$	
★★★★	$20\% \leq n < 30\%$	$119.86 < P \leq 136.99$	
★★★	$10\% \leq n < 20\%$	$136.99 < P \leq 154.11$	
★★ (includes NR)	$0\% \leq n < 10\%$	$154.11 < P \leq 171.20$	
★	(Normative reference not achieved)	$P > 171.20$	

Notes

1: When transmission output is 10.0 W X 2

2: When transmission output is 5.0 W X 2

[7] LTE Base Station Equipment

Figure of merit: $E = \text{total transmission output (W)} / \text{average primary input power (W)}$

Assessment scale	Rate of reduction vs. power consumption at NR	Average power consumption normative reference (W) for segregated 20W	Average power consumption normative reference (W) for integrated 20W
------------------	---	--	--

		equipment (Note 1)	equipment (Note 1)
★★★★★	$n \geq 30\%$	$P \leq 413.38$	$P \leq 610.02$
★★★★	$20\% \leq n < 30\%$	$413.38 < P \leq 472.44$	$610.02 < P \leq 697.16$
★★★	$10\% \leq n < 20\%$	$472.44 < P \leq 531.49$	$697.16 < P \leq 784.31$
★★ (includes NR)	$0\% \leq n < 10\%$	$531.49 < P \leq 590.55$	$784.31 < P \leq 871.46$
★	Normative reference not achieved	$P > 590.55$	$P > 871.46$

Assessment scale	Rate of reduction vs. power consumption at NR	Average power consumption normative reference (W) for segregated 10W equipment (Note 2)	
★★★★★	$n \geq 30\%$	$P \leq 607.81$	
★★★★	$20\% \leq n < 30\%$	$607.81 < P \leq 694.64$	
★★★	$10\% \leq n < 20\%$	$694.64 < P \leq 781.47$	
★★ (includes NR)	$0\% \leq n < 10\%$	$781.47 < P \leq 868.31$	
★	Normative reference not achieved	$P > 868.31$	

Notes

- 1: When transmission output is $20\text{ W} \times 2$
- 2: When transmission output is $10\text{ W} \times 2$

[8] 3G/LTE Multi-Radio Base Station Equipment

Figure of merit: $E = \text{total transmission output (W)} / \text{average primary input power (W)}$

Assessment scale	Rate of reduction vs. power consumption at NR	Average power consumption normative reference (W) for segregated 10W equipment (Note 1)	
★★★★★	$n \geq 30\%$	$P \leq 237.28$	
★★★★	$20\% \leq n < 30\%$	$237.28 < P \leq 271.18$	
★★★	$10\% \leq n < 20\%$	$271.18 < P \leq 305.08$	
★★ (includes NR)	$0\% \leq n < 10\%$	$305.08 < P \leq 338.98$	
★	Normative reference not achieved	$P > 338.98$	

Notes

1: When transmission output is $10 W \times 2$

[9] LTE-Advanced Base Station Equipment

Figure of merit: $E = \text{maximum throughput (Mbps)} / \text{average power consumption (W)}$

Assessment scale	Rate of reduction vs. power consumption at NR	Average power consumption normative reference (W) for segregated 10W equipment (24 sectors type) (Note 1)	
★★★★★	$n \geq 15\%$	$P \leq 6,737.11$	
★★★★	$10\% \leq n < 15\%$	$6,737.11 < P \leq 7,133.41$	
★★★	$5\% \leq n < 10\%$	$7,133.41 < P \leq 7,529.71$	
★★ (includes NR)	$0\% \leq n < 5\%$	$7,529.71 < P \leq 7,926.02$	
★	Normative reference not achieved	$P > 7,926.02$	

Notes

1: When transmission output is $10 W \times 2$

[10] External Power Source

Figure of merit: Average conversion efficiency $\eta = (\eta_{25} + \eta_{50} + \eta_{75} + \eta_{100}) / 4$

Standard voltage (6V and above)

Assessment scale	Rate of reduction vs. power consumption at NR	Average conversion efficiency η (%)
★★★★★	$n \geq 30\%$	$\eta \geq 0.05778 \ln(P_{no}) - 0.0012 P_{no} + 0.746$
★★★★	$20\% \leq n < 30\%$	$0.0628 \ln(P_{no}) - 0.00129 P_{no} + 0.719 \leq \eta < 0.05778 \ln(P_{no}) - 0.0012 P_{no} + 0.746$
★★★	$10\% \leq n < 20\%$	$0.0674 \ln(P_{no}) - 0.00136 P_{no} + 0.694 \leq \eta < 0.0628 \ln(P_{no}) - 0.00129 P_{no} + 0.719$
★★ (includes NR)	$0\% \leq n < 10\%$	$0.071 \ln(P_{no}) - 0.0014 P_{no} + 0.67 \leq \eta < 0.0674 \ln(P_{no}) - 0.00136 P_{no} + 0.694$
★	Normative reference not achieved	$\eta < 0.071 \ln(P_{no}) - 0.0014 P_{no} + 0.67$

(Note) P_{no} : Nameplate Output Power (W)

Low voltage (less than 6V)

Assessment scale	Rate of reduction vs. power consumption at NR	Average conversion efficiency η (%)
★★★★★	$n \geq 30\%$	$\eta \geq 0.00694 \ln(P_{no}) - 0.00127 P_{no} + 0.694$

★★★★★	$20\% \leq n < 30\%$	$0.0745 \ln(P_{no}) - 0.00130 P_{no} + 0.664 \leq \eta < 0.00694 \ln(P_{no}) - 0.00127 P_{no} + 0.694$
★★★★	$10\% \leq n < 20\%$	$0.0793 \ln(P_{no}) - 0.00136 P_{no} + 0.636 \leq \eta < 0.0745 \ln(P_{no}) - 0.00130 P_{no} + 0.664$
★★★ (includes NR)	$0\% \leq n < 10\%$	$0.0834 \ln(P_{no}) - 0.0014 P_{no} + 0.609 \leq \eta < 0.0793 \ln(P_{no}) - 0.00136 P_{no} + 0.636$
★	Normative reference not achieved	$0.0834 \ln(P_{no}) - 0.0014 P_{no} + 0.609$

(Note) P_{no}: Nameplate Output Power (W)

[11] Rectifier

Figure of merit: $TEER = (\eta_{30} + \eta_{40} + \eta_{50} + \eta_{60} + \eta_{70} + \eta_{80}) / 6 \times 1,000$

Single-phase AC100V input, 48V output rectifier

Assessment scale	Rate of reduction vs. power consumption at NR	Figure of merit (TEER)
★★★★★★	$n \geq 45\%$	$TEER \geq 926$
★★★★★	$30\% \leq n < 45\%$	$907 \leq TEER < 926$
★★★★	$15\% \leq n < 30\%$	$889 \leq TEER < 907$
★★★ (includes NR)	$0\% \leq n < 15\%$	$872 \leq TEER < 889$
★	Normative reference not achieved	$TEER < 872$

Single-phase AC200V input, 48V output rectifier

Assessment scale	Rate of reduction vs. power consumption at NR	Figure of merit (TEER)
★★★★★★	$n \geq 45\%$	$TEER \geq 929$
★★★★★	$30\% \leq n < 45\%$	$911 \leq TEER < 929$
★★★★	$15\% \leq n < 30\%$	$894 \leq TEER < 911$
★★★ (includes NR)	$0\% \leq n < 15\%$	$878 \leq TEER < 894$
★	Normative reference not achieved	$TEER < 878$

Three-phase AC200V/400V input, 48V output rectifier (output power capacity of less than 5kW)

Assessment Scale	Rate of reduction vs. power consumption at NR	Figure of Merit (TEER)
★★★★★★	$n \geq 30\%$	$TEER \geq 921$
★★★★★	$20\% \leq n < 30\%$	$911 \leq TEER < 921$
★★★★	$10\% \leq n < 20\%$	$901 \leq TEER < 911$
★★★ (includes NR)	$0\% \leq n < 10\%$	$891 \leq TEER < 901$
★	Normative reference not achieved	$TEER < 891$

Three-phase AC200V/400V input, 48V output rectifier (output power capacity of 5kW or more)

Assessment scale	Rate of reduction vs. power consumption at NR	Figure of merit (TEER)
★★★★★	$n \geq 30\%$	$TEER \geq 934$
★★★★	$20\% \leq n < 30\%$	$925 \leq TEER < 934$
★★★	$10\% \leq n < 20\%$	$916 \leq TEER < 925$
★★ (includes NR)	$0\% \leq n < 10\%$	$908 \leq TEER < 916$
★	Normative reference not achieved	$TEER < 908$

Three-phase AC200V/400V input, 380V output rectifier

Assessment scale	Rate of reduction vs. power consumption at NR	Figure of merit (TEER)
★★★★★	$n \geq 30\%$	$TEER \geq 960$
★★★★	$20\% \leq n < 30\%$	$955 \leq TEER < 960$
★★★	$10\% \leq n < 20\%$	$949 \leq TEER < 955$
★★ (includes NR)	$0\% \leq n < 10\%$	$944 \leq TEER < 949$
★	Normative reference not achieved	$TEER < 944$

[12]UPS

Figure of merit: average efficiency $\eta = (\eta_{25} + \eta_{50} + \eta_{75} + \eta_{100})/4$

Three-phase 200V with trans, 200 kVA or above and less than 500 kVA.

Assessment scale	Rate of reduction vs. power consumption at NR	Average conversion efficiency η
★★★★★	$n \geq 45\%$	$\eta \geq 93.7$
★★★★	$30\% \leq n < 45\%$	$92.2 \leq \eta < 93.7$
★★★	$15\% \leq n < 30\%$	$90.6 \leq \eta < 92.2$
★★ (includes NR)	$0\% \leq n < 15\%$	$89.2 \leq \eta < 90.6$
★	Normative reference not achieved	$\eta < 89.2$

Three-phase 200V with trans, 500 kVA or above.

Assessment scale	Rate of reduction vs. power consumption at NR	Average conversion efficiency η
★★★★★	$n \geq 45\%$	$\eta \geq 94.2$
★★★★	$30\% \leq n < 45\%$	$92.7 \leq \eta < 94.2$
★★★	$15\% \leq n < 30\%$	$91.3 \leq \eta < 92.7$

★★ (includes NR)	$0\% \leq n < 15\%$	$89.9 \leq \eta < 91.3$
★	Normative reference not achieved	$\eta < 89.9$

Three-phase 415V with trans, 500 kVA or above.

Assessment scale	Rate of reduction vs. power consumption at NR	Average conversion efficiency η
★★★★★	$n \geq 45\%$	$\eta \geq 94.8$
★★★★★	$30\% \leq n < 45\%$	$93.5 \leq \eta < 94.8$
★★★★	$15\% \leq n < 30\%$	$92.2 \leq \eta < 93.5$
★★ (includes NR)	$0\% \leq n < 15\%$	$90.9 \leq \eta < 92.2$
★	Normative reference not achieved	$\eta < 90.9$

Three-phase 200V transless, 200 kVA or above and less than 500 kVA.

Assessment scale	Rate of reduction vs. power consumption at NR	Average conversion efficiency η
★★★★★	$n \geq 30\%$	$\eta \geq 94.8$
★★★★★	$20\% \leq n < 30\%$	$94.1 \leq \eta < 94.8$
★★★★	$10\% \leq n < 20\%$	$93.4 \leq \eta < 94.1$
★★ (includes NR)	$0\% \leq n < 10\%$	$92.7 \leq \eta < 93.4$
★	Normative reference not achieved	$\eta < 92.7$

Three-phase 415V transless, 200 kVA or above and less than 500 kVA.

Assessment scale	Rate of reduction vs. power consumption at NR	Average conversion efficiency η
★★★★★	$n \geq 45\%$	$\eta \geq 97.5$
★★★★★	$30\% \leq n < 45\%$	$96.8 \leq \eta < 97.5$
★★★★	$15\% \leq n < 30\%$	$96.1 \leq \eta < 96.8$
★★ (includes NR)	$0\% \leq n < 15\%$	$95.5 \leq \eta < 96.1$
★	Normative reference not achieved	$\eta < 95.5$

Three-phase 415V transless, 500 kVA or above.

Assessment scale	Rate of reduction vs. power consumption at NR	Average conversion efficiency η
★★★★★	$n \geq 45\%$	$\eta \geq 97.9$
★★★★★	$30\% \leq n < 45\%$	$97.3 \leq \eta < 97.9$
★★★★	$15\% \leq n < 30\%$	$96.8 \leq \eta < 97.3$
★★ (includes NR)	$0\% \leq n < 15\%$	$96.2 \leq \eta < 96.8$
★	Normative reference not achieved	$\eta < 96.2$

[13] Servers

Figure of merit: Energy efficiency ratio $E_n = \exp(0.65 \times \ln(\text{Eff}_{\text{CPU}}) + 0.3 \times \ln(\text{Eff}_{\text{Memory}}) + 0.05 \times \ln(\text{Eff}_{\text{storage}}))$

Assessment Scale	Rate of improvement vs. energy efficiency at NR	Energy efficiency ratio per category E_n
		All categories (1-9)
★★★★★	$n \geq 30\%$	$0.3 \leq (E_n - E) / E$
★★★★	$20\% \leq n < 30\%$	$0.2 \leq (E_n - E) / E < 0.3$
★★★	$10\% \leq n < 20\%$	$0.1 \leq (E_n - E) / E < 0.2$
★★ (includes NR)	$0\% \leq n < 10\%$	$0 \leq (E_n - E) / E < 0.1$
★	Normative reference not achieved	$(E_n - E) / E < 0$

[14] Storage Equipment

Figure of merit:

Energy efficiency ratio $E_n = \text{power consumption (W)} / \text{storage capacity (GB)}$

Category IV and V

Assessment Scale	Rate of reduction vs. power consumption at NR	Energy consumption efficiency E_n	Notes
★★★★★	<u>$n \geq 60\%$</u>	<u>$E_n \leq E \times 0.4$</u>	Normative references E (W/GB) are based on the table under 5.2.8.1 (3) Normative References.
★★★★	<u>$40\% \leq n < 60\%$</u>	<u>$E \times 0.4 < E_n \leq E \times 0.6$</u>	
★★★	<u>$20\% \leq n < 40\%$</u>	<u>$E \times 0.6 < E_n \leq E \times 0.8$</u>	
★★ (includes NR)	<u>$0\% \leq n < 20\%$</u>	<u>$E \times 0.8 < E_n \leq E$</u>	
★	<u>Normative reference not achieved</u>	<u>$E < E_n$</u>	

Category VI

Assessment Scale	Rate of reduction vs. power consumption at NR	Energy consumption efficiency E_n	Notes
★★★★★	<u>$n \geq 30\%$</u>	<u>$E_n \leq E \times 0.7$</u>	Normative references E (W/GB) are based on the table under 5.2.8.1 (3) Normative References.
★★★★	<u>$20\% \leq n < 30\%$</u>	<u>$E \times 0.7 < E_n \leq E \times 0.8$</u>	
★★★	<u>$10\% \leq n < 20\%$</u>	<u>$E \times 0.8 < E_n \leq E \times 0.9$</u>	
★★ (includes NR)	<u>$0\% \leq n < 10\%$</u>	<u>$E \times 0.9 < E_n \leq E$</u>	
★	<u>Normative reference not achieved</u>	<u>$E < E_n$</u>	

4.2 Effort and Assessment Criteria for the “Eco ICT Logo” (for details, see 7.2)

<Mandatory items>

Type of effort		Assessment criteria
Preparation of a voluntary ecological action plan	1	Has a voluntary ecological action plan stipulating various efforts directed at reducing CO ₂ emissions through energy conservation been created and is it being executed?
	2	Does the ecological policy include specific efforts stipulating numerical targets for the reduction of CO ₂ emissions through energy conservation?
	3	Is the ecological policy documented and disseminated inside and outside of the company? Does the company carry out activities to inform and enlighten its employees? Is the company working to raise ecological awareness?
	4	Does the company disclose the individual activities listed in its voluntary ecological action plan along with implementation and achievement status to the general public?
Efforts relating to procurement	5	In regard to ICT equipment and data center services, has the company prepared a procurement standard based on the assessment specifications outlined in this Guideline that takes energy conservation into consideration? Is procurement carried out in accordance to the standard?
	6	Is the company cognizant of energy conservation in procuring office equipment, supplies and logistics (e.g., green purchasing)?
Promotion regime	7	In relation to efforts to reduce CO ₂ emissions through energy conservation, has the company assigned a person or department responsible for such matters?
	8	Is there a regime in place using internal audits or other means to keep appropriate track of the implementation of measures and achievement of targets set forth in the voluntary ecological action plan?

<Recommended items>

Other ecological activities	9	Are ecologically-friendly efforts being made other than activities to save energy?
	10	Is the company involved in ecological preservation activities in collaboration with local communities?

4.3 Image of Guideline Implementation

- (1) Flow leading to public disclosure of check list by telecommunications services providers and use of the “Eco ICT Logo” would proceed.

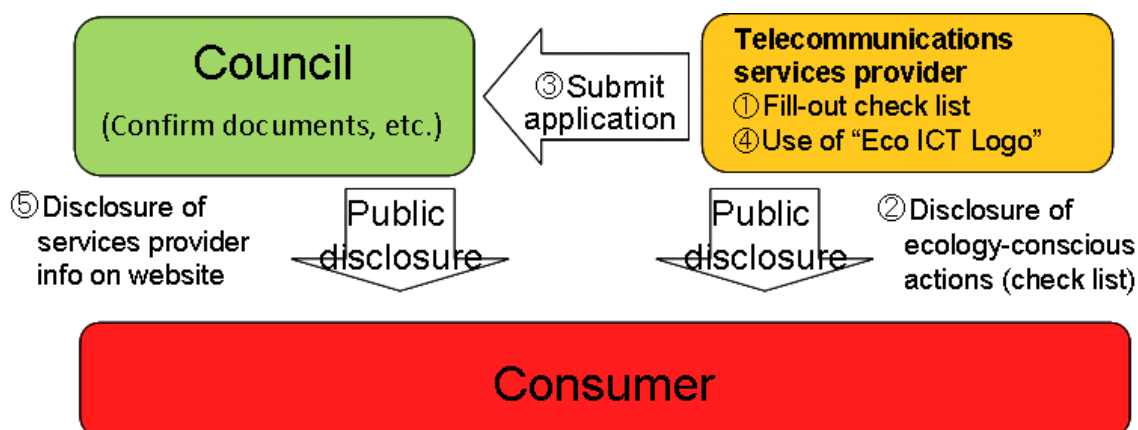

Use of the “Eco ICT Logo” shall be limited to the following:

- > Telecommunications services providers.
- > A person who operates a telecommunications business defined under the Telecommunications Business Act, other than Telecommunications services providers.
- > Neither of the above, but operating business related to telecommunications services using substantial ICT equipment AND recognized by the Council.

5. Assessment Standards

5.1 Assessment standards

5.1.1 Scope

The scope of ICT equipment covered in this Guideline shall be equipment used mainly by telecommunications services providers to provide their services, covering network equipment, power equipment, server equipment and storage equipment. The addition and/or elimination of equipment categorization and more detailed sub-categorizations shall be reviewed as deemed appropriate.

【Network equipment】

Equipment categorization	Category	Equipment covered	Notes
Broadband routers (with VNP functions)	TBD	TBD	
Broadband routers (without VNP functions)	A (WAN : Ether, LAN : Ether)	Wired router	Equipment classifications and sub-categories shall be aligned with top runner assessment standard
	B (WAN : Ether, LAN : VoIP)	Wired routers with VoIP	
	C (WAN : Ether, LAN : wireless)	Wireless routers	
	D (WAN : ADSL, LAN : Ether)	ADSL routers	
	E (WAN : ADSL, LAN : VoIP)	ADSL routers with VoIP	
	F (WAN : ADSL, LAN : wireless)	Wireless ADSL routers	
Layer-2 switch (chassis-type)	TBD	TBD	
Layer-2 switch (box-type)	A (with SNMP management and IP filtering functions)	Layer-2 switch	Equipment classifications and sub-categories shall be aligned with top runner assessment standard
	B (with SNMP management, w/o IP filtering functions)	Layer-2 switch	
	C (With web or other management functions)	Layer-2 switch	
	D (without management functions)	Layer-2 switch	
Transport equipment	WDM equipment	DWDM equipment	Equipment categorizations shall be aligned with ATIS

		CWDM equipment	Equipment categorizations shall be aligned with ATIS
	Converged packet optical equipment	Converged packet optical equipment (packet & TDM functions)	
		Converged packet optical equipment (packet & TDM & WDM functions)	
PON equipment	GE-PON	OLT	
		ONU	
Broadband base station equipment	WiMAX	WiMAX base stations	
	LTE	LTE base stations	
	3G/LTE	3G/LTE Multi-Radio Base Station Equipment	
	LTE-Advanced	LTE-Advanced base stations	
	<u>5G</u>	<u>5G base stations</u>	

Note: TBD=To be determined

【Power equipment】

Equipment categorization	Category	Equipment name	Notes
Power equipment	External power source	AC adapter	Excludes rechargers
	Rectifier equipment	Rectifier equipment	
	UPS	UPS	

【Server equipment】

Equipment categorization	Category	Equipment name	Notes
Server equipment	1	x86 (Number of CPU sockets=1)	Equipment sub-categorizations shall be aligned with top runner assessment standard
	2	x86 (Number of CPU sockets=2)	
	3	x86 (Number of CPU sockets=4)	
	4	SPARC (Number of CPU sockets=1)	
	5	SPARC (Number of CPU sockets=2)	
	6	SPARC (Number of CPU sockets=4)	

	7	Power (Number of CPU sockets=1)	
	8	Power (Number of CPU sockets=2)	
	9	Power (Number of CPU sockets=4)	

【Storage equipment】

Equipment categorization	Category	Equipment covered	Notes
Storage equipment (subsystems)	<u>IV</u>	Number of disk drives= <u>between 2 and 11</u>	Equipment categorization and sub-categorizations shall be aligned with top runner assessment standard
	<u>V</u>	Number of disk drives=12 or more, including the 3.5-inch disk drive	
	<u>VI</u>	Number of disk drives=12 or more, only the 2.5-inch disk drive	

5.1.2 Stance on other assessment standards

In regard to specific assessment standards for the equipment subject to this Guideline, in cases where appropriate standards covering practices by telecommunications services providers already existed, those existing standards were adopted. For equipment with no existing assessment standards, assessment standards for similar equipment were used as reference.

5.2 Equipment Definitions, Figures of Merit, Normative References and Measurement Methods

5.2.1 Routers

5.2.1.1. Broadband router

(1) Equipment Definition

Among routers which relay data on ISO's OSI (Open System Interconnection) layer 3 (network layer) using IP addresses included in the destination information of packets, routers with an effective transmission rate of no more than 200 Mbps (no more than 100 Mbps for wireless routers) and:

- having no VPN (Virtual Private Network) functions; and
- having no more than two phone lines if equipped with VoIP (Voice over Internet Protocol) functions.

The following is the definition of effective transmission rate.

Non-wireless: the sum of maximum down link and up link transmission rates (bps) including overhead (control information)

Wireless: down link transmission rate (bps) including overhead (control information)

Broadband routers as defined by the Energy Conservation Law

Equipment Definition of Energy Conservation Law

Equipment for sending and receiving electronic telecommunication signals having the function of transmitting electronic telecommunication signals to a path determined to be the most appropriate depending on the state of each path etc. from among available paths to reach the destination equipment (limited to those used almost exclusively for the Internet; when having a communication terminal equipment connect to the Internet through a phone line, excluding those used to connect to the Internet by calling an Internet service provider to have the said communication terminal equipment connect to the Internet, and others set forth under Ministerial Ordinance Number 39 from the Ministry of Economy, Trade and Industry*1).

*1: Exclusions provided under Ministerial Ordinance Number 39 from the Ministry of Economy, Trade and Industry are as follows.

- [1] Those that do not transmit/exchange Internet protocol packets
- [2] In transmitting Internet protocol packets, those with the maximum value of the sum of the number of signal bits of the said packets exceeding 200Mbps/s (excluding those specified in 6)) (Those having an effective transmission rate exceeding 200Mbit/s)
- [3] Those that do not allow asynchronous transfer mode equipment to be easily removed.
- [4] Those having the function of impressing high-frequency current of 10kHz or higher.
- [5] Those having at least three of those used for sending and receiving sound among connection ports for sending and receiving electric telecommunications signals (excluding those using Internet protocol)
- [6] In transmitting Internet protocol packets wirelessly, those with the maximum value of the sum of the number of signal bits of the said packets exceeding 100Mbit/s
- [7] Those having the function to use satellites

- [8] Those having the function of transmitting 53 or more subcarrier frequencies by using orthogonal frequency division multiplexing method.
 [9] Those having the function of setting a Virtual Private Network.
 [10] Those designed to be built into an electronic computer or other item.

(2) Figure of Merit

Adopt the assessment standard based on the top runner method (2009 Ministerial Notification No. 226 from the Ministry of Economy, Trade and Industry) for routing equipment specified in the Energy Conservation Law. Specific figures of merit are as follows.

$$\text{Energy efficiency ratio } E = \text{Power consumption } P \text{ (W)}$$

(3) Normative References

[1] Method for determining normative references

Adopt the assessment standard based on the top runner method for routing equipment specified in the Energy Conservation Law.

[Normative References]

Specific normative references are as follows.

Category			Energy efficiency ratio E(W)
Type of interface on WAN side	Type of interface on LAN side	Category name	
Ethernet only	Ethernet only	A	4.0
	Ethernet with VoIP	B	5.5
	Ethernet with wireless function	C	When transmitting on wireless 2.4GHz band only: $E = 0.10 \times X2 + 3.9$ When transmitting on wireless 5 GHz band only: $E = 0.15 \times X5 + 3.9$ When transmitting the two frequencies mentioned above simultaneously: $E = 0.10 \times X2 + 0.15 \times X5 + 5.1$
ADSL only	Ethernet only	D	7.4
	Ethernet with VoIP	E	7.4
	Ethernet with wireless function	F	8.8

Notes

- 1: "WAN side" refers to the side of the port connected to a network such as the Internet.
 "LAN side" refers to the side of the port connected to other equipment.
- 2: E, X2 and X5 represent the following values:
 E: Reference energy efficiency ratio (unit: W)

- X2: 2.4 GHz wireless output (unit: mW/MHz)
 X5: 5 GHz wireless output (unit: mW/MHz)
- 3: In Category C, for equipment capable of transmission by selecting 2.4 or 5 GHz wireless band, use the calculation formula for the frequency band with a higher effective transmission rate in (4) Measurement Methodology to calculate the value for the reference energy efficiency ratio.

[Approximate Date for Achieving Normative References]

The end of Fiscal Year 2010 [adopted the target fiscal year per the reference on routing equipment (2009 Ministerial Notification No. 226 from the Ministry of Economy, Trade and Industry), specified in the Energy Conservation Law]

[2] Assessment scale references

The rate of reduction versus the normative reference shall determine the threshold. In the assessment scale, the rank covering the normative reference shall be ★★.

Assessment scale	Rate of reduction vs. power consumption at NR	Energy efficiency ratio per category E_n (W)						Notes
		A	B	C	D	E	F	
★★★★★	$n \geq 30\%$	$E_n \leq E \times 0.7$						NR E (W) per table under (3) [1] Normative References
★★★★★	$20\% \leq n < 30\%$	$E \times 0.7 < E_n \leq E \times 0.8$						
★★★	$10\% \leq n < 20\%$	$E \times 0.8 < E_n \leq E \times 0.9$						
★★ (includes NR)	$0\% \leq n < 10\%$	$E \times 0.9 < E_n \leq E$						
★	(Normative reference not achieved)	$E_n > E$						

(Note) In calculating energy efficiency ratio, calculate values to the first decimal place.

(4) Measurement Methodology

Measurement methods are as follows and coincide with those set forth under the 2009 Ministerial Notification Number 226 from the Ministry of Economy, Trade and Industry, which sets forth, among other things, assessment standards for vendors in relation to the stipulations of the Energy Conservation Law for routing equipment.

- [1] To measure energy efficiency, measure power consumption at maximum effective transmission rate. Conditions for measuring power consumption and maximum effective transmission rate are as follows.
- The maximum value of the sum of the number of packets per second output to the WAN side and the number of packets per second output to the LAN side.
 - A 1,500 byte packet shall be transmitted for measurement. However, if the

transmission of a 1,500 byte packet is not possible, use the maximum packet length.

- (c) Use IP packets for unicast transmission.
- (d) The data pattern of the header section is arbitrary. Use 0 for all data patterns of the packet to be measured.
- (e) When measuring power consumption, it shall be acceptable to transmit the minimum packets suited to the maximum effective transmission rate of the router.
- (f) Enable routing of packets received by the router. Routing is the relay of data to a destination determined by the IP address on a network using the layer 3 (network layer) of a model indicated in the Basic Reference Model 6 of Open Systems Interconnection stipulated in Japan Industrial Standard X5003. Upon performing the relay, the TTL value, which is the header information associated with an IP address, shall be deducted and relayed to a different data link.
- (g) Removable components and functions that can be disabled without sacrificing the basic performance and functioning of the router shall be removed or disabled, respectively, for the measurement.
- (h) Ports not involved in the measurement can be linked down.
- (i) The peripheral temperature shall fall within the range of 16 to 32°C. However, for wireless routers the range shall be 0 to 40°C.
- (j) Power voltage shall be within the range of $\pm 10\%$ of rated input voltage (100V or 200V).
- (k) Use rated frequency for AC power source frequency.
- (l) Conduct measurements with the router in a stationary state.
- (m) For products using an AC power source, measure power consumption at the power plug.
- (n) In the case of AC power, use effective power as power consumption.

[2] Use the following conditions for routers with wireless capacity

- (a) Wireless transmission direction shall be from the WAN side to the LAN side.
- (b) If there are multiple wireless LAN interfaces capable of operating simultaneously, operate them simultaneously.
- (c) Use a configuration that disables functions such as data compression and output power adjustment.
- (d) Use maximum link speed of the router.
- (e) Take measurements on the tested equipment using packet generators.

(5) Assessment Result and Assessment Scale Ranking

[1] Assessment result

The assessment result shall be the figure of merit actually measured by the vendor according to 5.2.1.1(4) Measurement Methodology.

[2] Assessment scale ranking

The assessment scale ranking (★-★★★★★) shall be based on normative reference and assessment result.

[3] Variance in assessment result

Values specified in 2009 Ministerial Notification No. 226 from the Ministry of Economy, Trade and Industry (2010 METI Notification No. 149 revised version) shall apply.

The specific range of permissible variance in assessment results shall be $x/115$ of the energy efficiency ratio of individual equipment, where x is a figure of 100 or more.

As indicated in the diagram below, this means that where the assessment result of the individual equipment is 100, the measurement value of the energy efficiency ratio (energy consumption (W)) cannot exceed 115.

In other words, the range of permissible variance of the indicated value is +15% or less.

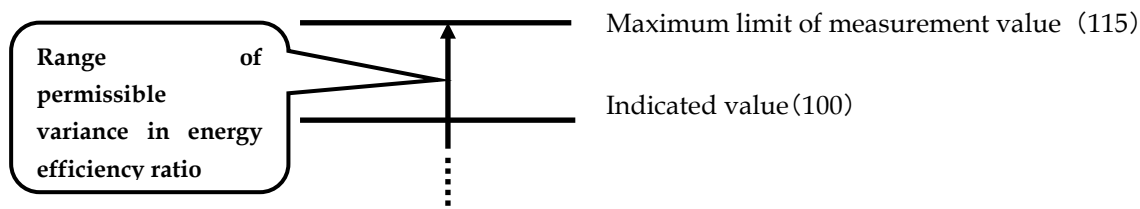

5.2.2 Switching Equipment

5.2.2.1. Layer 2 (L2) Switches (box type)

(1) Equipment Definition

Among equipment which relays data on the network using ISO's OSI (Open System Interconnection) layer 2 (data link layer), box type equipment using the MAC address included in the destination information of the packet and has three or more communication ports.

Equipment Definition in Energy Conservation Law

Equipment for sending and receiving electronic telecommunication signals having the function of transmitting electronic telecommunication signals to a path determined separately for each destination from among two or more paths capable of transmission (limited to those used almost exclusively for the Internet; however excluding those capable of wireless telecommunication and others set forth under Ministerial Ordinance Number 39 from the Ministry of Economy, Trade and Industry*1).

*1: Exclusions provided under Article 48 (21) of Ministerial Ordinance Number 39 from the Ministry of Economy, Trade and Industry (exclusions from specified equipment) are as follows.

- [1] Those that do not transmit and switch Ethernet frames
- [2] Those that transmit and switch Internet protocol packets

- [3] Those with connection ports for sending and receiving electric telecommunications signals having at least half of the connection ports utilize a two line connection
- [4] Those designed to be built into a housing, electronic computer or other item.
- [5] Those for controlling equipment that relay electrical telecommunications signal wirelessly
- [6] Those set forth by the Minister of Economy Trade and Industry that are primarily for supplying power.

(2) Figure of merit

Adopt the assessment standard based on the top runner method for switching equipment (2009 Ministerial Notification No. 227 from the Ministry of Economy, Trade and Industry), identified as a specified equipment in the Energy Conservation Law.

$$\text{Energy efficiency } E = \text{power consumption} / \text{maximum effective transmission rate (W /Gbps)}$$

(3) Normative References

[1] Method for determining normative references

Adopt the assessment standard based on the top runner method for switching equipment, identified as specified equipment in the Energy Conservation Law.

[Normative References]

Specific normative references are as follows.

However, the normative references do not apply to models with P_d/P_{SA} , P_d/P_{SB} , P_d/P_{SC} or P_d/P_{SD} in excess of 16, per the following.

Category				Normative Reference: Standard energy efficiency ratio (W/Gbps)
Management functions	Type of management functions	IP filtering functions	Category name	
With management functions	With SNMP functions	With IP filtering functions	A	$E = (\alpha_A + P_A) / T$
		No IP filtering functions	B	$E = (\alpha_B + P_B) / T$
	With Web management and other management functions		C	$E = (\alpha_C + P_C) / T$
No management functions			D	$E = (\alpha_D + P_D) / T$

Notes

- 1: "Management functions" refers to functions for a network manager to acquire such information as network components and communications status for the purpose of operating the network efficiently.
- 2: Values for α_A , α_B , α_C and α_D shall be calculated using the following formula.

$$\alpha_A = 0.578 \times X1 + 1.88 \times X2 + 15.9 \times X3 + \beta_A$$

$$\alpha_B = 0.375 \times X1 + 1.88 \times X2 + \beta_B$$

$$\alpha_C = 0.375 \times X1 + 1.133 \times X2 + \beta_C$$

$$\alpha_D = 0.272 \times X1 + 1.133 \times X2 + \beta_D$$

The value for α_A , α_B , α_C or α_D shall be 3 in cases where the equipment has only a 100 Mbps port, or where the equipment has a 100 Mbps port and a 1 Gbps port and the value for α_A , α_B , α_C and α_D is less than 3. Furthermore, the value for α_A , α_B , α_C or α_D shall be 4.5 in the event the equipment has only a 1Gbps port and the value for α_A , α_B , α_C or α_D is less than 4.5.

- 3: The value for X1 is the number of ports (unit: number of ports) with a line speed of 100 Mbps. The value for X2 is the number of ports (unit: number of ports) with a line speed of 1 Gbps. The value for X3 is the number of ports (unit: number of ports) with a line speed of 10 Gbps.
- 4: Use the values provided in the following table for β_A , β_B , β_C and β_D based on the appropriate categorization.

	β_A	β_B	β_C	β_D
Has only a 100Mbps port	3.976	3.4	3.4	0.824
Has only a 1Gbps port	9.94	-5.07	-2.074	-2.074
Has only a 10Gbps port	0	0	0	0
Has a 100Mbps port and one 1 Gbps port	2.276	1.7	2.447	1.494
Has a 100Mbps port and two or more 1 Gbps ports	0.576	0	1.494	1.494
Has a 1Gbps port and a 10Gbps port	-10.24	0	0	0

- 5: The values for P_A , P_B , P_C and P_D shall be calculated using the following formula.

$$P_A = (0.0347 \times P_d / P_{SA}) / (1 - 0.0347 \times P_d / P_{SA}) \times \alpha_A$$

$$P_B = (0.0347 \times P_d / P_{SB}) / (1 - 0.0347 \times P_d / P_{SB}) \times \alpha_B$$

$$P_C = (0.0347 \times P_d / P_{SC}) / (1 - 0.0347 \times P_d / P_{SC}) \times \alpha_C$$

$$P_D = (0.0347 \times P_d / P_{SD}) / (1 - 0.0347 \times P_d / P_{SD}) \times \alpha_D$$
- 6: The values for P_{SA} , P_{SB} , P_{SC} and P_{SD} shall be calculated using the following formula.

$$P_{SA} = \alpha_A \times 0.85 + 1$$

$$P_{SB} = \alpha_B \times 0.85 + 1$$

$$P_{SC} = \alpha_C \times 0.85 + 1$$

$$P_{SD} = \alpha_D \times 0.85 + 1$$
- 7: P_d represents the value for maximum power supply (unit: W) for power over Ethernet. If the equipment has no power over Ethernet function, use 0.
- 8: T represents the value for maximum effective transmission rate (unit: Gbps) when the frame length is 1,518 bytes.

[Approximate Date for Achieving Normative References]

End of Fiscal Year 2011 (adopted the target fiscal year per the standard on switching equipment (2009 Ministerial Notification No. 227 from the Ministry of Economy, Trade and Industry), specified in the Energy Conservation Law)

[2] Assessment scale references

Set a threshold using the rate of reduction versus the power consumption at normative reference (Note 1). In assessment scale, the rank including normative reference shall be ★★.

(Note 1) Rate of reduction of power consumption vs. NR shall be comparable for equipment with similar maximum effective transmission rates.

Assessment scale	Rate of reduction vs. power consumption at NR	Energy efficiency ratio per category En (W/Gbps)				Notes
		A	B	C	D	
★★★★★	$n \geq 30\%$	$E_n \leq E \times 0.7$				Normative Reference E (W/Gbps) per table under (3) Normative References
★★★★	$20\% \leq n < 30\%$	$E \times 0.7 < E_n \leq E \times 0.8$				
★★★	$10\% \leq n < 20\%$	$E \times 0.8 < E_n \leq E \times 0.9$				
★★ (includes NR)	$0\% \leq n < 10\%$	$E \times 0.9 < E_n \leq E$				
★	(Normative reference not achieved)	$E_n > E$				

(Note) In calculating energy efficiency ratio, calculate values to the first decimal place.

(4) Measurement Methodology

Measurement conditions are as follows taking into account the substance of the 2009 Ministerial Notification Number 227 from the Ministry of Economy, Trade and Industry, which sets forth judgment standards, among other things, for manufacturers of switching equipment per the stipulations of the Energy Conservation Law.

- [1] For energy efficiency, use the value resulting from dividing the value expressed in W, representing power consumption during maximum effective transmission rate when the frame length to be measured is 1,518 bytes, by a value expressed in Gbps, representing the aforementioned effective transmission rate.
- [2] Conditions for measuring power consumption and maximum effective transmission rate are as follows.
 - (a) The value for maximum effective transmission rate is calculated using the following formula.

$$T = R \times (L+20) \times 8/10^9$$
 In this formula, T, R and L represent the following values.
 T: Maximum effective transmission rate when the frame length is 1,518 bytes
 R: The total number of frame output per second from all ports
 L: Frame length (unit: bytes)
 - (b) Set switch so as to perform switching of received frames. Switching is the relay of data on a network using layer 2 (data link layer) of a reference model indicated in Basic Reference Model 6 of Open Systems Interconnection stipulated in Japan Industrial Standard X5003. Specifically, relay is performed referring to the MAC address.
 - (c) Use frames for unicast transmission.
 - (d) The data pattern of the header section is arbitrary. Use 0 for all data

patterns of the frame to be measured.

- (e) Measurement dependent on type of cascade connection at the ports are permissible. In such cases, calculate maximum effective transmission rate considering the number of cascade-connected ports.
- (f) When measuring energy efficiency ratio, it is acceptable to transmit the minimum frames required according to the maximum effective transmission rate of the switch.
- (g) Components that can be removed and functions that can be disabled without sacrificing the basic performance and functioning of the switch shall be removed or disabled, respectively, for the measurement.
- (h) Ports not used in the measurement can be linked down.
- (i) The peripheral temperature shall fall within the range of 16 to 32°C.
- (j) Power voltage shall be within the range of $\pm 10\%$ of rated input voltage (100V or 200V) if the power source is AC and within the range of DC-57V to DC-40.5V if the power source is DC.
- (k) Use rated frequency for AC power source frequency.
- (l) Conduct measurements with the switch in a stationary state.
- (m) For products using an AC power source, measure power consumption at the power plug terminal.
- (n) In the case of AC power, use effective power as power consumption.

(5) Assessment Result and Assessment Scale Ranking

[1] Assessment result

The assessment result shall be the figure of merit actually measured by the vendor according to 5.2.2.1(4) Measurement Methodology.

[2] Assessment scale ranking

The assessment scale ranking (★-★★★★★) shall be based on normative reference and assessment result.

[3] Variance in assessment result

Values specified in 2009 Ministerial Notification No. 226 from the Ministry of Economy, Trade and Industry (2010 METI Notification No. 149 revised version) shall apply.

The specific range of permissible variance in assessment results shall be $x/115$ of the energy efficiency ratio of individual equipment, where x is a figure of 100 or more.

As indicated in the diagram below, this means that where the assessment result of the individual equipment is 100, the measurement value of the energy efficiency ratio (energy consumption (W)) cannot exceed 115.

In other words, the range of permissible variance of the indicated value is +15% or less.

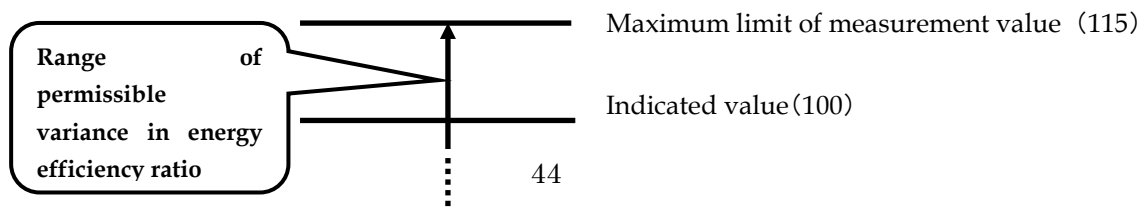

5.2.3 Transport Equipment

5.2.3.1. WDM Equipment

(1) Equipment Definition

- WDM equipment is a product that performs info-communication functions over a single fiber-optic cable by multiplexing multiple optic signals of different wavelengths.
- WDM equipment from recent years may include devices that integrate OSI reference models from layer 2 (data link) to the layer 3 (network). Due to the difficulty of defining a standard device configuration, here, WDM equipment refers to devices equipped for only OSI layer 1 (physical).
- This guideline applies to WDM equipment used in terrestrial systems. Submarine systems are exempt. Furthermore, relay equipment is exempt because relay equipment consumes less power compared to terminal equipment.

[Functional Configuration Subject to This Guideline]

WDM equipment is categorized as follows based on WDM multiplexing method, OADM function and OADM method.

WDM multiplexing method	OADM function (Note 1)	OADM method	Classification	
DWDM (Note 2)	Yes	Fixed	①	DWDM with Fixed OADM
		Reconfigurable	②	DWDM with ROADM
		Optical Cross Connect	③	DWDM with OXC
	No	—	④	DWDM (Point-Point)
CWDM (Note 3)	Yes	Fixed	⑤	CWDM with Fixed OADM
		Reconfigurable	⑥	CWDM with ROADM
	No	—	⑦	CWDM (Point-Point)

Notes

- 1: Point-Point optical multiplexing/demultiplexing is considered to be included within OADM functions, but categories are expressed in terms of with or without OADM.
- 2: DWDM (Dense Wavelength Division Multiplexing): WDM equipment where wavelength multiplexing is conducted at intervals specified by ITU-T G.694.1.
- 3: CWDM (Coarse Wavelength Division Multiplexing): WDM equipment where wavelength multiplexing is conducted at intervals specified by ITU-T G.694.2.

Among the above categories, ② DWDM with ROADM and ⑦ CWDM (Point-Point) are subject to this Guideline, both of which are expected to exhibit energy-

saving impact and for which future demand is forecast.

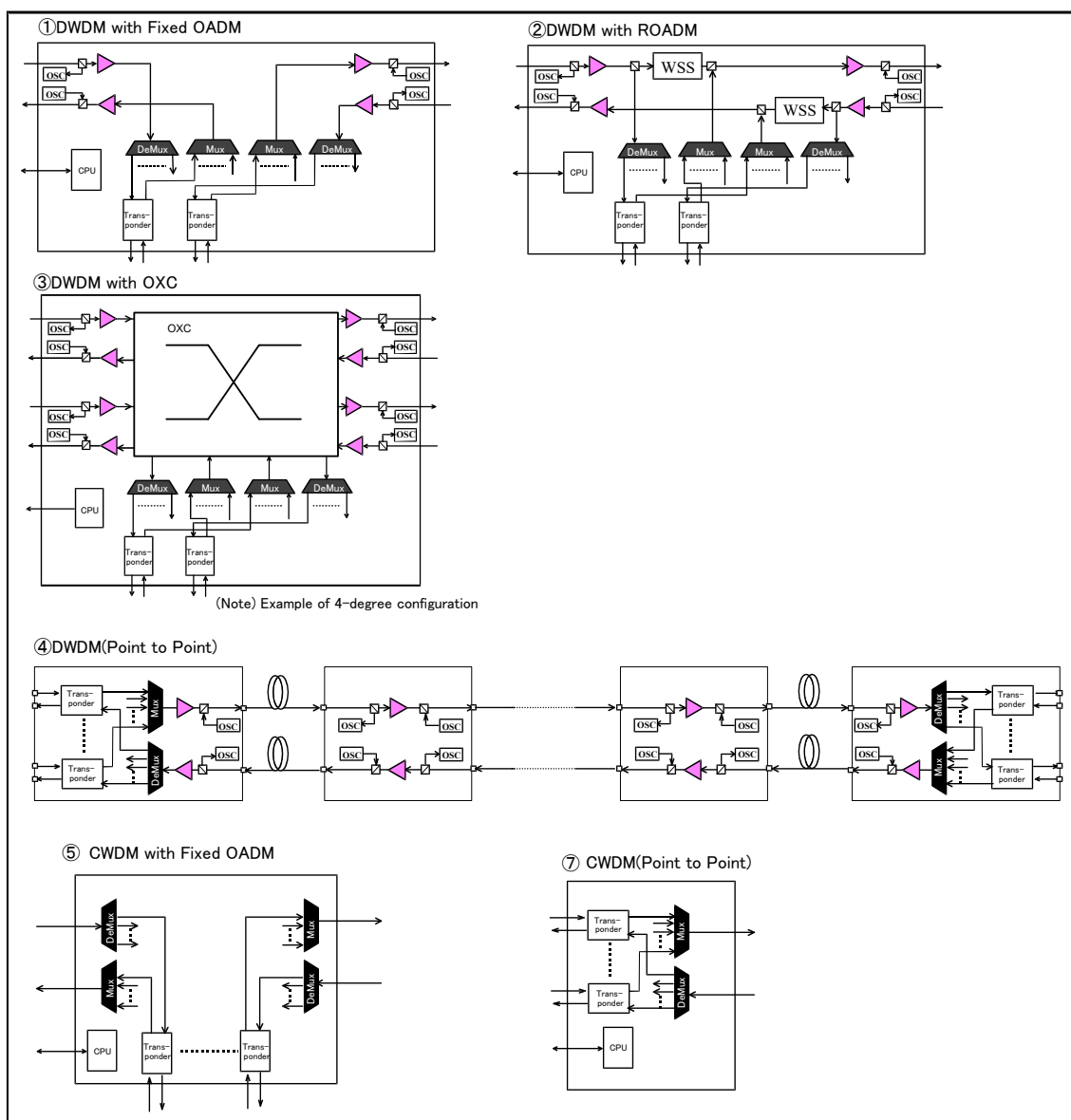

(2) Figures of merit

The figure of merit for WDM equipment shall be the maximum throughput at average power consumption.

Since this figure of merit for transport equipment is the same as that stipulated by ATIS (Alliance for Telecommunications Industry Solutions), its relevancy shall be noted.

The figure of merit, TEER (Telecommunications Energy Efficiency Ratio) (Note 1) for transport equipment stipulated by ATIS is as follows.

$$\begin{aligned}
 TEER_{CERT} &= D_{TEER} / P_{TEER-CERT} \\
 &= \sum Di / \{(P_{CERT-0} + P_{CERT-50} + P_{CERT-100}) / 3\}
 \end{aligned}$$

$TEER_{CERT}$: Certified TEER measured at a specific configuration (Note 2)

D_{TEER} : Total data rate (bps)

$P_{TEER-CERT}$: Measured power consumption (W)

D_i : Data rate (bps) at a given interface i

P_{CERT-0} : Measured power consumption (W) at a 0% data usage rate

$P_{CERT-50}$: Measured power consumption (W) at a 50% data usage rate

$P_{CERT-100}$: Measured power consumption (W) at a 100% data usage rate

(Note 1): ATIS-0600015.2009: General TEER base standard

(Note 2): ATIS-0600015.02.2009: Transport product category TEER

This figure of merit applies not only to WDM equipment but also to “transport equipment” including SONET/SDH equipment and the like.

<For WDM Equipment>

DWDM figure of merit: $TEER = \text{maximum throughput (Gbps)} / \text{average power consumption (W)}$

CWDM figure of merit: $TEER = \text{maximum throughput (Gbps)} / \text{average power consumption (W)}$

Note: Calculate average power consumption = (power consumption at full wavelength + power consumption at one wavelength) / 2.

Peak throughput is total throughput at full wavelength.

With WDM equipment, unlike packet interface cards, it is common to guarantee constant 100% transport; therefore,

$$P_{CERT-0} = P_{CERT-50} = P_{CERT-100}.$$

Thus, $TEER_{CERT}$ in WDM equipment under ATIS is in essence as follows.

$$TEER_{CERT} = D_{TEER} / P_{TEER-CERT}$$

= maximum transmission capacity / power consumption when configured for maximum transmission capacity

(This is provided as a ROADM system example for ATIS-0600015.02.2009.)

In evaluating the power consumption of equipment, measure power consumption at one wavelength and at full wavelength, so as to provide visibility into low power consumption in common portions such as the optical amplifier and the optical multiplexer/demultiplexer, and use the following for average power consumption.

Average power consumption = (power consumption at full wavelength + power consumption at one wavelength) / 2

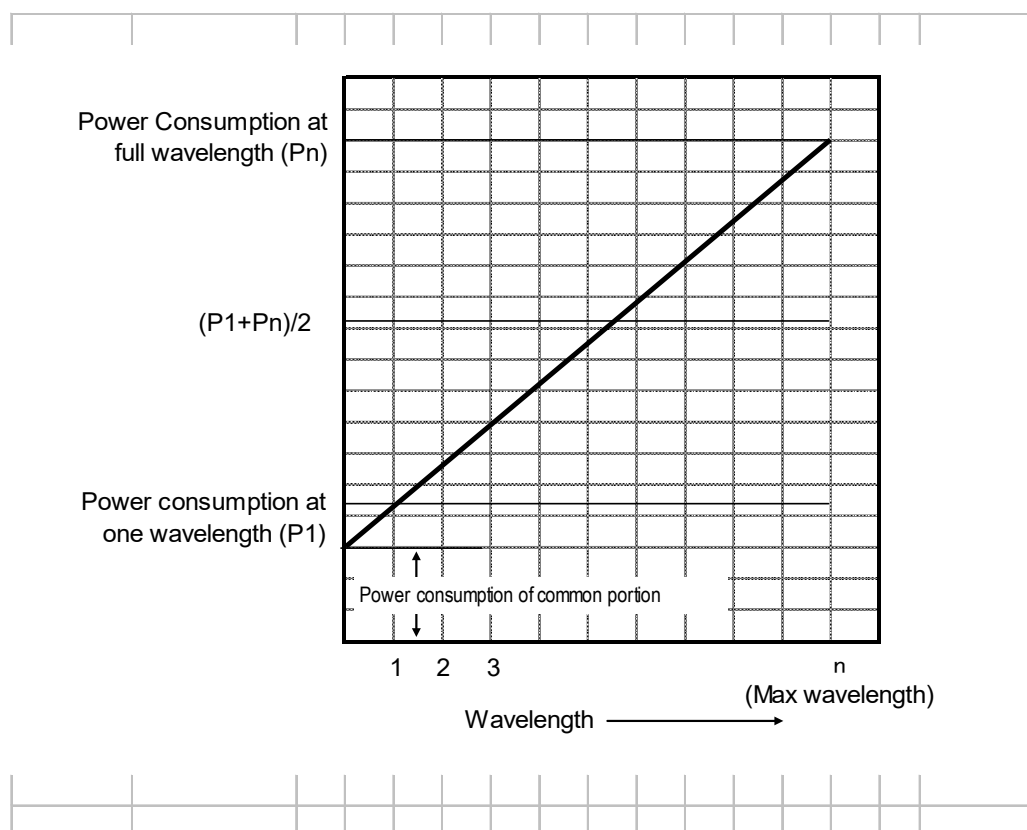

Given that equipment configuration differs by vendor, it is preferable to use the following parameters, which rely largely on power consumption and enable stipulation through external interface.

- > Total throughput on client side.
- > Transmission distance of a section (Use 0.25dB/km)

Generally, it is believed power consumption rises with an increase in these parameters. However, in the case of DWDM, the increase in power consumption in relation to transmission distance of a section is believed to be small in light of the overall figure.

For that reason, use as a metric value that results from dividing maximum throughput value by average power consumption and do not consider transmission distance of a section.

[Definition of Throughput]

Throughput is defined as the total effective client signal rate (converted to a single direction) passing through the device (does not include closed and attached FEC within WDM).

For example, a 40 wave “DWDM with ROADM” set at 10 Gbps per wave on the WDM side would have a total client signal rate (maximum throughput) of 10 Gbps x 40 ch x 2 directions = 800 Gbps. The total client signal rate (maximum throughput) of a 4 wave “CWDM (Point to Point)” would be 10 Gbps x 4 ch x 1 direction = 40 Gbps.

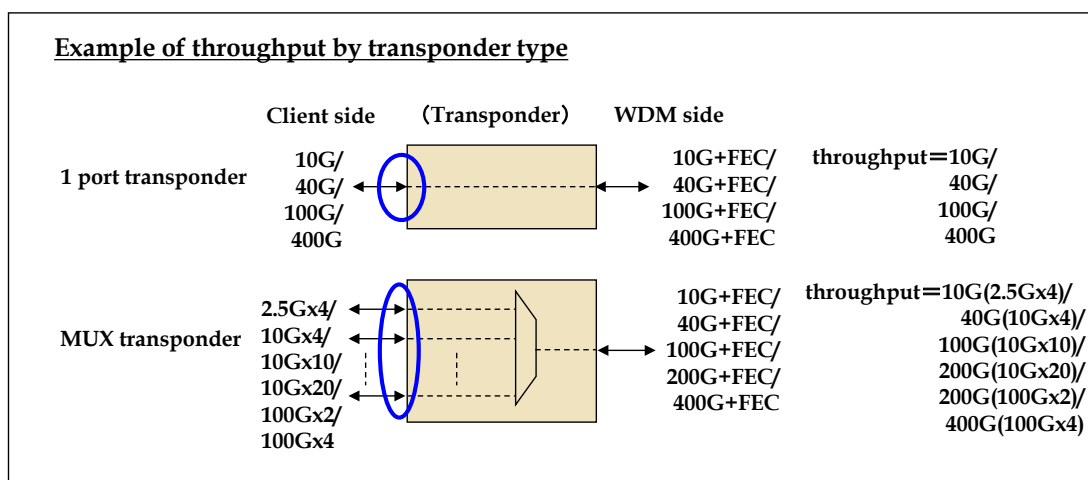

(2) Normative References

[1] Method for determining normative references

Normative references for DWDM and CWDM equipment shall be values derived by accounting for technological trends to the average metric values for current products (CIAJ survey).

DWDM equipment (400 Gbps) is newly added.

The modulation method is 16QAM.

FEC is power consumption at the maximum ability.

QAM : Quadrature Amplitude Modulation

FEC : Forward Error Correction

[Normative References]

DWDM equipment (10 Gbps) : 0.33 (Gbps/W)

DWDM equipment (40 Gbps) : 0.40 (Gbps/W)

DWDM equipment (100 Gbps) : 0.86 (Gbps/W)

DWDM equipment (200 Gbps) : 1.79 (Gbps/W)

DWDM equipment (400 Gbps) : 3.15 (Gbps/W)

CWDM equipment (10 Gbps) : 0.57 (Gbps/W)

[Approximate Date for Achieving Normative References]

End of Fiscal Year 2016 : DWDM equipment (10Gbps/40Gbps/100Gbps)
and CWDM equipment (10 Gbps)

End of Fiscal Year 2019 : DWDM equipment (200 Gbps)

End of Fiscal Year 2022 : DWDM equipment (400 Gbps)

[2] Assessment scale references

Set a threshold using the rate of reduction versus the power consumption at normative reference. In assessment scale, the rank including normative reference shall be ★★.

Reference example 1) Average power consumption at normative reference for

800 Gbps DWDM equipment (10 Gbps) is 2,424.24 W.

Reference example 2) Average power consumption at normative reference for 3,200 Gbps DWDM equipment (40 Gbps) is 8,000.00 W.

Reference example 3) Average power consumption at normative reference for 8,000 Gbps DWDM equipment (100 Gbps) is 9,302.32 W.

Reference example 4) Average power consumption at normative reference for 16,000 Gbps DWDM equipment (200 Gbps) is 8,938.54 W.

Reference example 5) Average power consumption at normative reference for 32,000 Gbps DWDM equipment (400 Gbps) is 10,158.73 W.

Reference example 6) Average power consumption at normative reference for 40 Gbps CWDM equipment (10 Gbps) is 70.17 W.

Assessment scale	Rate of reduction vs. power consumption at NR	Average power consumption (W) for 800 GbpsDWDM (10 Gbps)	Average power consumption (W) for 3,200 GbpsDWDM (40 Gbps)
★★★★★	$n \geq 30\%$	$P \leq 1,696.96$	$P \leq 5,600.00$
★★★★	$20\% \leq n < 30\%$	$1,696.96 < P \leq 1,939.39$	$5,600.00 < P \leq 6,400.00$
★★★	$10\% \leq n < 20\%$	$1,939.39 < P \leq 2,181.81$	$6,400.00 < P \leq 7,200.00$
★★ (includes NR)	$0\% \leq n < 10\%$	$2,181.81 < P \leq 2,424.24$	$7,200.00 < P \leq 8,000.00$
★	Normative reference not achieved	$P > 2,424.24$	$P > 8,000.00$

(Note) In power consumption, calculate values to the second decimal place.

Assessment scale	Rate of reduction vs. power consumption at NR	Average power consumption (W) for 8,000 GbpsDWDM (100 Gbps)	Average power consumption (W) for 16,000 GbpsDWDM (200 Gbps)
★★★★★	$n \geq 30\%$	$P \leq 6,511.62$	$P \leq 6,256.97$
★★★★	$20\% \leq n < 30\%$	$6,511.62 < P \leq 7,441.85$	$6,256.97 < P \leq 7,150.83$
★★★	$10\% \leq n < 20\%$	$7,441.85 < P \leq 8,372.08$	$7,150.83 < P \leq 8,044.68$
★★ (includes NR)	$0\% \leq n < 10\%$	$8,372.08 < P \leq 9,302.32$	$8,044.68 < P \leq 8,938.54$
★	Normative reference not achieved	$P > 9,302.32$	$P > 8,938.54$

(Note) In power consumption, calculate values to the second decimal place.

Assessment scale	Rate of reduction vs. power consumption at NR	Average power consumption (W) for 32,000 Gbps DWDM (400 Gbps)	Average power consumption (W) for 40 GbpsCWDM (10 Gbps)
★★★★★	$n \geq 30\%$	$P \leq 7,111.11$	$P \leq 49.11$
★★★★	$20\% \leq n < 30\%$	$7,111.11 < P \leq 8,126.98$	$49.11 < P \leq 56.13$
★★★	$10\% \leq n < 20\%$	$8,126.98 < P \leq 9,142.85$	$56.13 < P \leq 63.15$
★★ (includes NR)	$0\% \leq n < 10\%$	$9,142.85 < P \leq 10,158.73$	$63.15 < P \leq 70.17$
★	Normative reference not	$P > 10,158.73$	$P > 70.17$

	achieved		
--	----------	--	--

(Note) In power consumption, calculate values to the second decimal place.

(4) Measurement Methodology

[1] Measurement configuration

- (a) Subject: 1 equipment (not in units of frames or shelves)
- (b) Mounting: Configure and equip with function blocks for maximum throughput
- (c) Power source: Redundant configuration (DC)
- (d) Optic cable connection:
 - > All mounted within device
 - > Corresponds to measuring equipment on client side
 - > Corresponds to return path of transmission
- (e) Basic configuration
 - > Use Ring for DWDM with ROADM
 - > Use point to point for CWDM

Example of Measurement Configuration

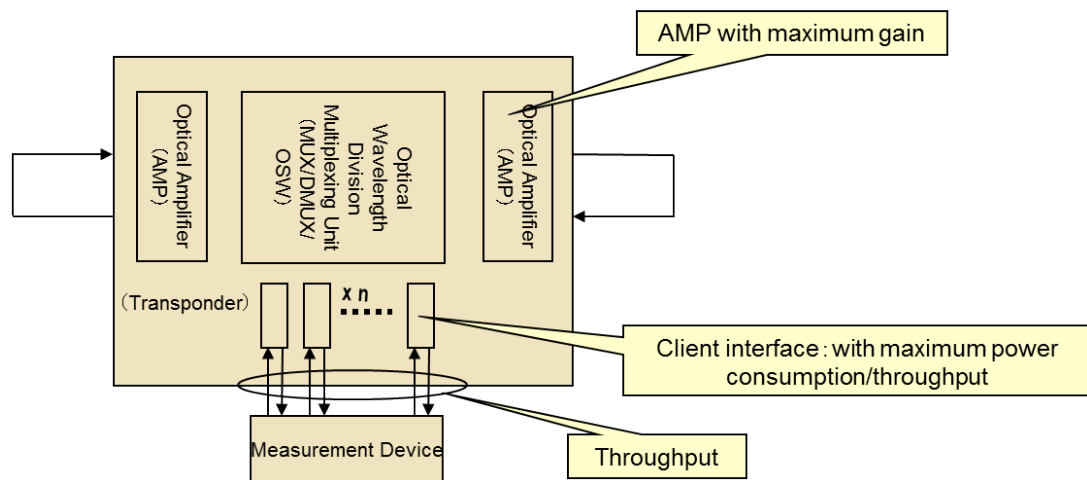

[2] Measurement conditions

- (a) Environmental conditions: Temperature of $25^{\circ}\text{C} \pm 5^{\circ}\text{C}$ (no stipulations for humidity or air pressure)
- (b) Measurement precision: $\pm 1\%$
- (c) Test voltage: $-48\text{V} \pm 1\text{V}$ in DC
- (d) Slot mounting: Full mounting (use maximum mounting regardless of redundancy)
 - Maximum mounting refers to the state that maximizes equipment throughput.

- Where different types of optical amps exist, equip with that which provides maximum distance of a span.
 - Mount all cables
- (e) Load conditions:
- > 1 wave (minimum wavelength count but maximum bandwidth)
 - > Full wavelength (maximum bandwidth)
- (f) Points to note in testing: Stabilize by running for 15 continuous minutes under stipulated conditions before taking measurements.

(5) Assessment Result and Assessment Scale Ranking

[1] Assessment result

The assessment result shall be the figure of merit actually measured by the vendor according to 5.2.3.1(4) Measurement Methodology.

[2] Assessment scale ranking

The assessment scale ranking (★-★★★★★) shall be based on normative reference and assessment result.

[3] Variance in assessment result

Permissible variance due to differences in equipment (units) shall be determined in the future.

The average of the actual measurement values for the figure of merit attained by the vendor shall be submitted as the assessment result.

5.2.3.2. Converged Packet Optical Equipment

(1) Equipment Definition

Converged packet optical equipment refers to a type of transport equipment which transports (switches) multiple types of signals such as [1] packet signals, [2] TDM signals and [3] WDM signals.

The scope of this guideline shall cover devices which handle [1] packet signals and [2] TDM signals as part of both packet and TDM dual functionality. The definition of these types of signals shall be as follows:

[1] Packet signals

Signals whose label includes a MAC address relayed via ISO OSI layer 2 (data link layer) or an IP address relayed via ISO OSI layer 3 (network layer) or routing information.

[2] TDM signals

Time division multiplexing (TDM) signals, such as STM-n/OC-n/OTU-n signals defined in SDH/SONET/OTN, as well as analog signals conveying image or voice over telephone lines.

[3] WDM signals

Wavelength division multiplexing signals, which multiplex multiple optic signals with different wavelengths.

TDM: Time Division Multiplexing
WDM: Wavelength Division Multiplexing
ISO: International Organization for Standardization
OSI: Open Systems Interconnection
MAC: Media Access Control
SDH: Synchronous Digital Hierarchy
SONET: Synchronous Optical Network
STM: Synchronous Transport Module
OC: Optical Carrier
OTN: Optical Transport Network
OTU: Optical Channel Transport Unit

<< Converged packet optical equipment I with both packet signal and TDM signal functions >>

[Device configuration]

- The scope of this guideline shall cover the following four configuration models.

Model I: Configuration where TDM signals and packet signals in both directions are switched independently.

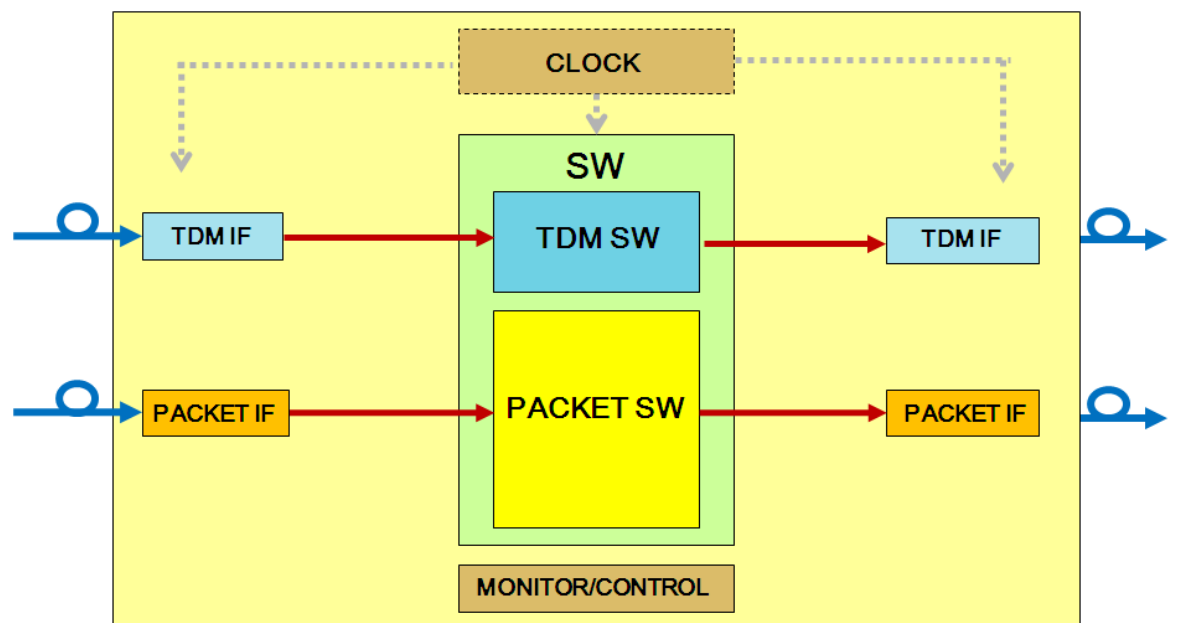

Model II: Configuration where some TDM signals are converted into packets and switched via the packet switch, or some packet signals are depacketed and switched via the TDM switch.

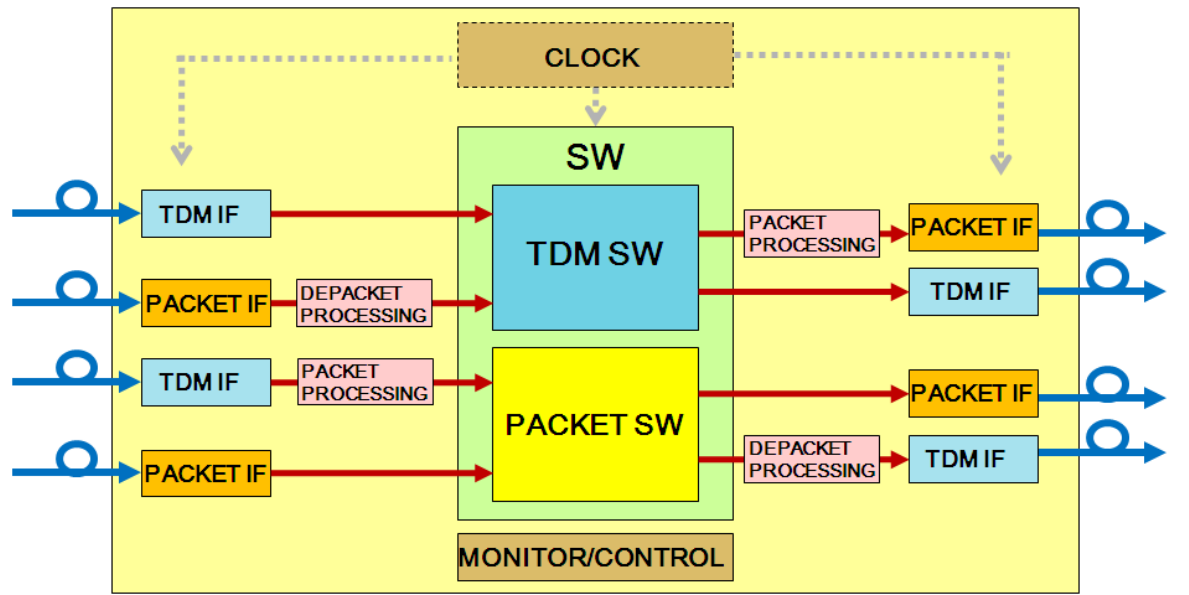

Model III: Configuration where all TDM signals are converted into packet signals and switched via the packet switch

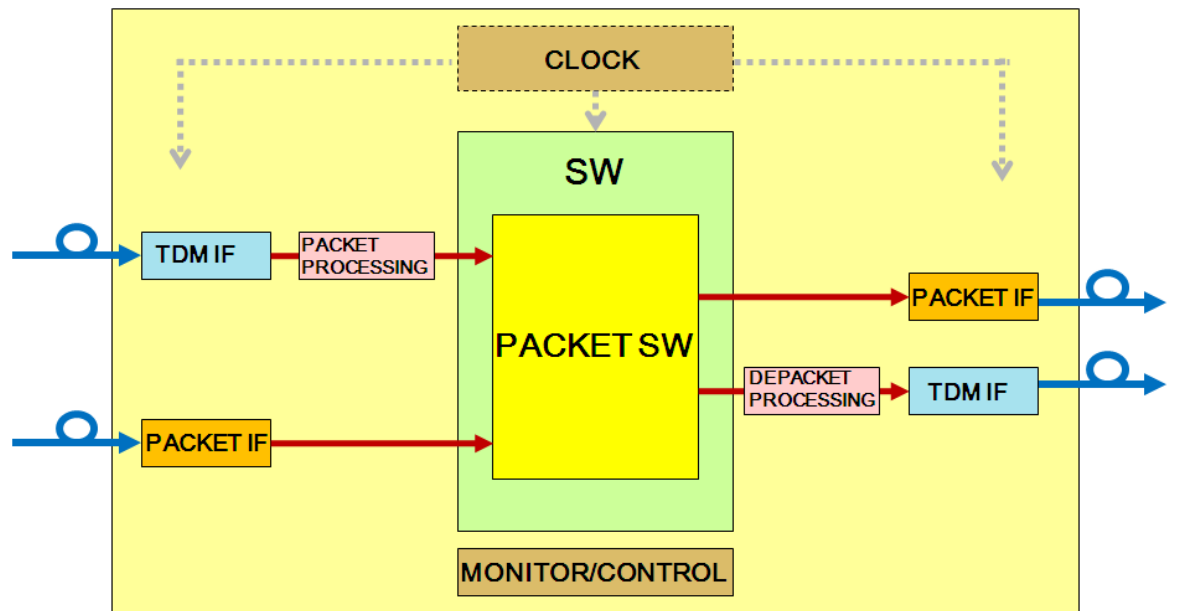

Model IV: Configuration where all packet signals are depacketed and switched via the TDM switch

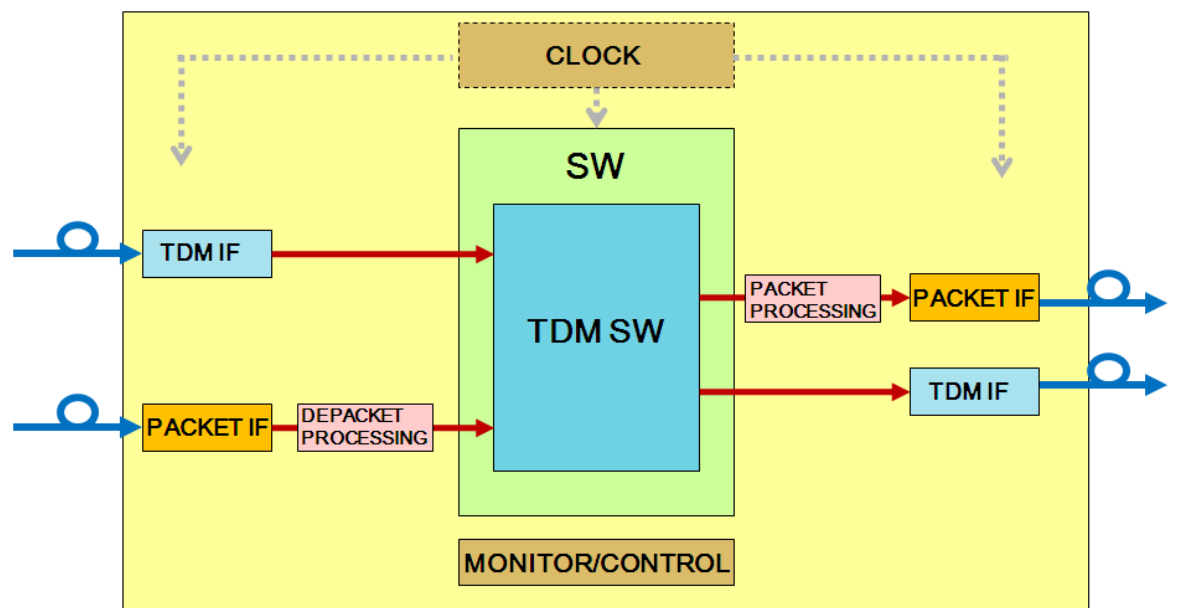

Network configuration example using converged packet optical equipment

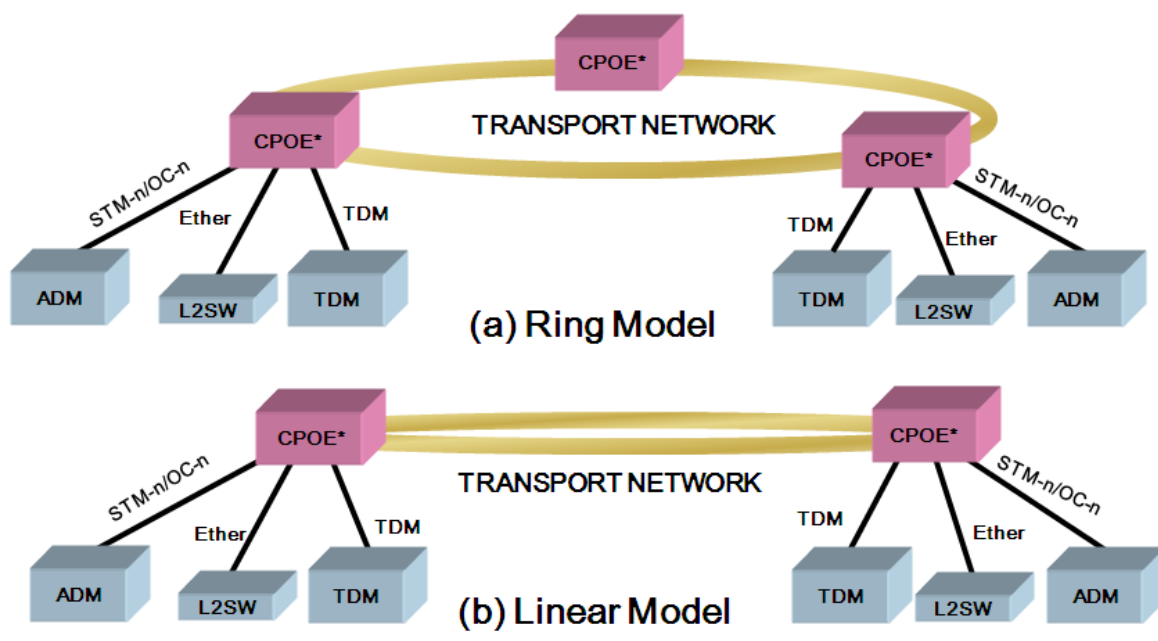

- The scope of this guideline includes transport network side optical transmission route interface in the ring/linear models above handling packet signals (MPLS/MPLS-TP/PBB-TE, etc.), but does not include equipment handling only TDM signals.

[Additional explanation of terminology]

- Ring: Refers to ring topology networks. Multiple equipment is connected in a ring configuration, where if transmission in one direction fails, the path can be

switched to the other direction in order to recover the signal. Linear: Refers to linear topology networks. A network where two or more equipment are connected in a linear configuration. In case of transmission route failure, a section of the route or the path between devices can be switched to another in order to recover the signal.

- MPLS: Multi Protocol Label Switching. IETF is working on standardization of this packet transfer technology using label switching. A label is added to the route information in the packet and signals are transported based on this label.
- MPLS-TP: Multi Protocol Label Switching - Transport Profile. Enhances maintenance and operability of the network by adding conditions for realizing SDH network-level quality, using the MPLS label transport technology.
- PBB-TE: Provider Backbone Bridge - Traffic Engineering. Configuration consisting of point-to-point relay on a PBB network defined by IEEE802.1ah.

(2) Figure of merit

- The figure of merit for converged packet optical equipment shall be the maximum throughput per average power consumption.

The ATIS figure of merit for transport equipment covers single-function equipment, such as WDM-only or TDM-only equipment, and does not indicate figure of merit for converged equipment with multiple function-capacity. However, the figure of merit for converged packet optical equipment for this Guideline shall be the ATIS figure of merit of "maximum throughput per average power consumption."

The figure of merit (TEER) designated by ATIS for transport equipment is as follows.

$$\begin{aligned} \text{TEER}_{\text{CERT}} &= D_{\text{TEER}} / P_{\text{TEER-CERT}} \\ &= \sum D_i / \{(P_{\text{CERT-0}} + P_{\text{CERT-50}} + P_{\text{CERT-100}}) / 3\} \end{aligned}$$

TEER_{CERT}: Certified TEER measured at a specific configuration

D_{TEER}: Total data rate (bps)

P_{TEER-CERT}: Measured power consumption (W)

D_i: Data rate (bps) at a given interface i

P_{CERT-0}: Measured power consumption (W) at a 0% data traffic utilization

P_{CERT-50}: Measured power consumption (W) at a 50% data traffic utilization

P_{CERT-100}: Measured power consumption (W) at a 100% data traffic utilization

< For converged packet optical equipment >

For converged packet optical equipment capable of both packet as well as TDM functions, interface cards are added depending on the data usage volume. Therefore, in general,

$$(P_{\text{CERT-0}} + P_{\text{CERT-50}} + P_{\text{CERT-100}})/3 \doteq (P_{\text{CERT-0}} + P_{\text{CERT-100}})/2$$

Thus, in practice, $\text{TEER}_{\text{CERT}}$ for converged packet optical equipment shall be as follows.

$$\begin{aligned} \text{TEER}_{\text{CERT}} &= D_{\text{TEER}} / P_{\text{TEER-CERT}} \\ &= \Sigma D_i / \{(P_{\text{CERT-0}} + P_{\text{CERT-100}})/2\} \\ &= \text{Maximum throughput} / \text{average power consumption} \end{aligned}$$

For converged packet optical equipment capable of both packet as well as TDM functions, if

$$\begin{aligned} \text{Packet function portion (A)} &= \text{Maximum throughput (Gbps) of packet functions} \\ &= \lceil \text{Port speed (Gbps)} \times \text{Number of ports} \times \text{Number of slots} \rceil \end{aligned}$$

$$\begin{aligned} \text{TDM function portion (B)} &= \text{Maximum throughput (Gbps) of TDM functions} \\ &= \lceil \text{Port speed (Gbps)} \times \text{Number of ports} \times \text{Number of slots} \rceil \end{aligned}$$

$$\begin{aligned} \text{The maximum throughput for converged packet optical equipment} \\ &= \sqrt{(A^2 + B^2)} / 2 \end{aligned}$$

$$\begin{aligned} \text{The average power consumption for converged packet optical equipment} \\ &= (P_{\text{idle}} + P_{\text{max}}) / 2 \end{aligned}$$

P_{idle} : Power consumption (W) of total equipment with no data throughput with minimum components and path configuration

P_{max} : Power consumption (W) of total equipment during main signal transmission with maximum component configuration

$$\begin{aligned} \text{Figure of merit: E} &= \text{Maximum throughput (Gpbs)} / \text{average power consumption} \\ &= \sqrt{(A^2 + B^2)} / 2 / \{(P_{\text{idle}} + P_{\text{max}}) / 2\} \end{aligned}$$

[Functional parts of converged packet optical equipment]

- 1) Type of interface
 - Select the maximum capacity each for packet and/or TDM interface.
 - Separate the packet switching component from the TDM switching component.
- 2) Type of functional parts
 - Packet functioning parts: the interface for transmitting and receiving packet signals.
 - TDM functioning parts: the interface for transmitting and receiving TDM signals.

(3) Normative reference

[1] Method for determining normative reference

The normative reference for converged packet optical equipment (packet and TDM functions) shall be values derived by accounting for technological trends to the average metric values based on products shipped in Fiscal Year 2011 (CIAJ survey).

[Normative reference]

Converged packet optical equipment (10Gbps) : 0.1009 (Gbps/W)

Converged packet optical equipment (100Gbps) : 0.2065 (Gbps/W)

[Approximate Date for Achieving Normative References]

End of Fiscal Year 2014

[2] Assessment scale references

Set a threshold using the rate of reduction versus the power consumption at normative reference. In assessment scale, the rank including normative reference shall be ★★.

Reference example 1) Average power consumption at normative reference for equipment with 50 Gbps packet function and 50 Gbps TDM function.

Assessment scale	Rate of reduction vs. power consumption at NR	Average power consumption (W) with 50 Gbps packet function and 50 Gbps TDM function
★★★★★	$n \geq 30\%$	$P \leq 346.87$
★★★★★	$20\% \leq n < 30\%$	$346.87 < P \leq 396.43$
★★★	$10\% \leq n < 20\%$	$396.43 < P \leq 445.98$
★★ (includes NR)	$0\% \leq n < 10\%$	$445.98 < P \leq 495.54$
★	Normative reference not achieved	$P > 495.54$

(Note) In power consumption, calculate values to the second decimal place.

Reference example 2) Average power consumption at normative reference for equipment with 1,600 Gbps packet function and 1,600 Gbps TDM function.

Assessment scale	Rate of reduction vs. power consumption at NR	Average power consumption (W) with 1,600 Gbps packet function and 1,600 Gbps TDM function
★★★★★	$n \geq 30\%$	$P \leq 5,423.72$
★★★★★	$20\% \leq n < 30\%$	$5,423.72 < P \leq 6,198.54$
★★★	$10\% \leq n < 20\%$	$6,198.54 < P \leq 6,973.36$
★★ (includes NR)	$0\% \leq n < 10\%$	$6,973.36 < P \leq 7,748.18$
★	Normative reference not achieved	$P > 7,748.18$

(Note) In power consumption, calculate values to the second decimal place.

(4) Measurement Methodology
 [1] Measurement configuration

[Example of maximum component configuration for measuring P_{max}]

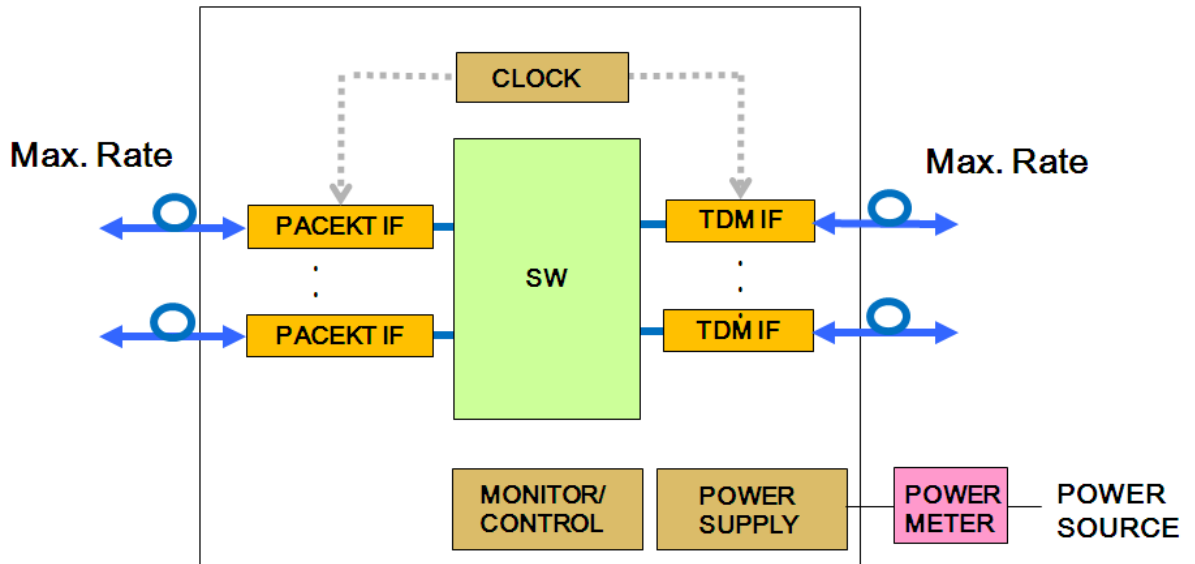

[Example of minimum component and path configuration for measuring P_{idle}]

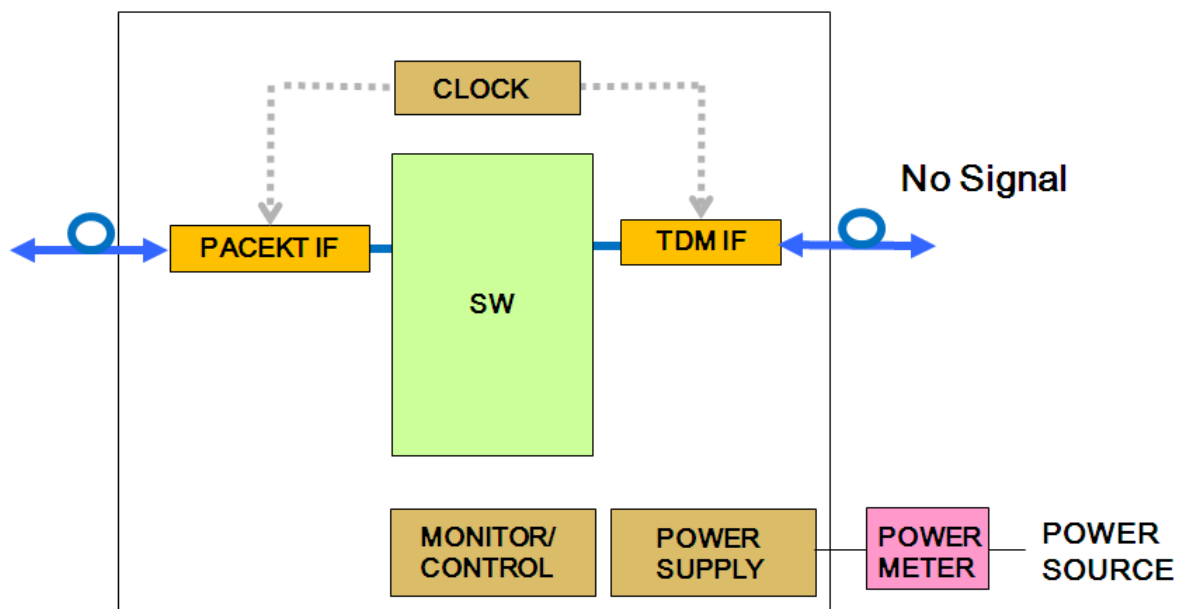

In the case of ring models, the configuration shall be set up with a single-side path.

[2] Measurement conditions

(a) Interface

1) Selection of the interface

- Select the interface where the transmission capacity calculated using the

following formula will be maximized for TDM and/or packet.

- Transmission capacity
= Port speed (Gbps) x Number of ports x Number of slots

2) Function combination patterns

- For the TDM interface and packet interface, conduct measurements selecting the configurable pattern at NNI side/UNI side from below
 - [1] TDM (NNI), TDM (UNI)
 - [2] TDM (NNI), packet (UNI)
 - [3] packet (NNI), TDM (UNI)
 - [4] packet (NNI), packet (UNI)
- Select the pattern in which maximum throughput will be reached for TDM/packet respectively.

(Reference example)

In the above combinations, “A” shall be the maximum throughput of the TDM functional part for the combination resulting in the maximum TDM throughput and “a” shall be the power consumption of that combination.

Furthermore, in the above combinations, “B” shall be the maximum throughput of the packet functional part for the combination resulting in the maximum packet throughput and “b” shall be the power consumption of that combination. Thus,

$$\text{Maximum throughput of the functional part} = \sqrt{(A^2+B^2)}/2$$

$$\text{Average power consumption} = (a + b)/2$$

Equipment name	Configuration	Total throughput (Gbps) of packet functional parts	Total throughput (Gbps) of TDM functional parts	Average power consumption of entire equipment			Interface combination (IF) when measuring P _{idle} and P _{max}
				Power consumption (W) at P _{idle}	Power consumption (W) at P _{max}	Average power consumption (W)	
A	Model I	-	40	P _{idle} [1]	P _{max} [1]	P [1]	TDM (NNI), TDM (UNI)
		-	20				
A	Model II	20	120	P _{idle} [2]	P _{max} [2]	P [2]	TDM (NNI), Packet (UNI)
A	Model III	20	20	P _{idle} [3]	P _{max} [3]	P [3]	Packet (NNI), TDM (UNI)
A	Model IV	80	-	P _{idle} [4]	P _{max} [4]	P [4]	Packet (NNI), Packet (UNI)
		80	-				

Maximum throughput of the TDM functional part for the entire equipment (A): 120

Maximum throughput of the packet functional part for the entire equipment (B): 80 + 80 = 160

Maximum throughput of the functional part: $\sqrt{(A^2+B^2)}/2 = 141.4$ (Gbps)

Average power consumption of the entire equipment = $(P [2] + P [4])/2$

- 3) Interface when measuring P_{\max} configuration
 - Use the interface selected in 1), and configure using maximum slot/maximum port.
 - 4) Interface when measuring P_{idle} configuration
 - Use the interface selected in 1), and configure using 1 slot/1 port I/O. In the case of ring models, set up with a single-side path or convert the result to 1 slot/1 port configuration.
 - 5) Configuration for redundancy
 - There is no specification of interface. When using an interface, calculate the transmission capacity with the redundant interface as part of the main unit.
 - There is no specification for common components (It shall be possible to have no common components).
 - (b) Transmission load
 - 1) Transmission load when measuring P_{\max}
 - Maximum rate when configured at maximum capacity
 - 2) Transmission load when measuring P_{idle}
 - Non-transmitting state when configured with minimum paths at minimum capacity
 - (c) Environmental conditions
 - Temperature: $25^{\circ}\text{C} \pm 5^{\circ}\text{C}$
 - Humidity: not stipulated
 - Air pressure: not stipulated
 - (d) Test voltage
 - DC - $48\text{V} \pm 1\text{V}$ or AC $100\text{V} \pm 10\%$ 50/60 Hz
 - (e) Number of equipment measured
 - There is no stipulation on number of equipment to be measured, but if multiple equipment is measured, indicate the average value.
 - (f) Number of measurements
 - There is no stipulation on number of measurements, but if measurements are taken multiple times, indicate the average value.
 - (g) Measurement precision
 - Not stipulated.
- (5) Assessment Result and Assessment Scale Ranking
- [1] Assessment result
The assessment result shall be the figure of merit actually measured by the vendor according to 5.2.3.2 (4) Measurement Methodology.
 - [2] Assessment scale ranking
The assessment scale ranking (★-★★★★★) shall be based on normative

reference and assessment result.

[3] Variance in assessment result

Permissible variance due to differences in equipment (units) shall be determined in the future.

The average of the actual measurement values for the figure of merit attained by the vendor shall be submitted as the assessment result.

<< Converged packet optical equipment II with packet signal, TDM signal and WDM signal functions >>

[Device configuration]

- Configured with converged packet optical I (packet SW and TDM SW) and WDM functional parts

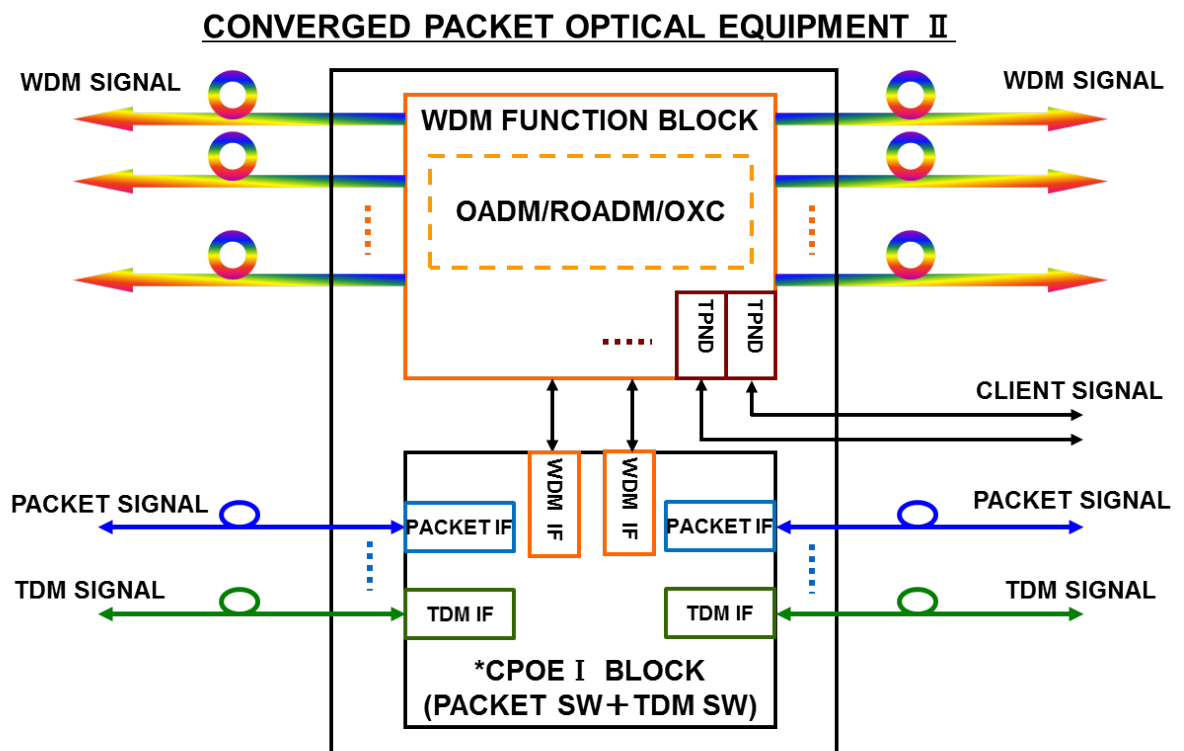

*CPOE I : CONVERGED PACKET OPTICAL EQUIPMENT I

Note: Converged packet optical equipment II can be composed of multiple converged packet optical equipment I.

Network configuration example using converged packet optical equipment

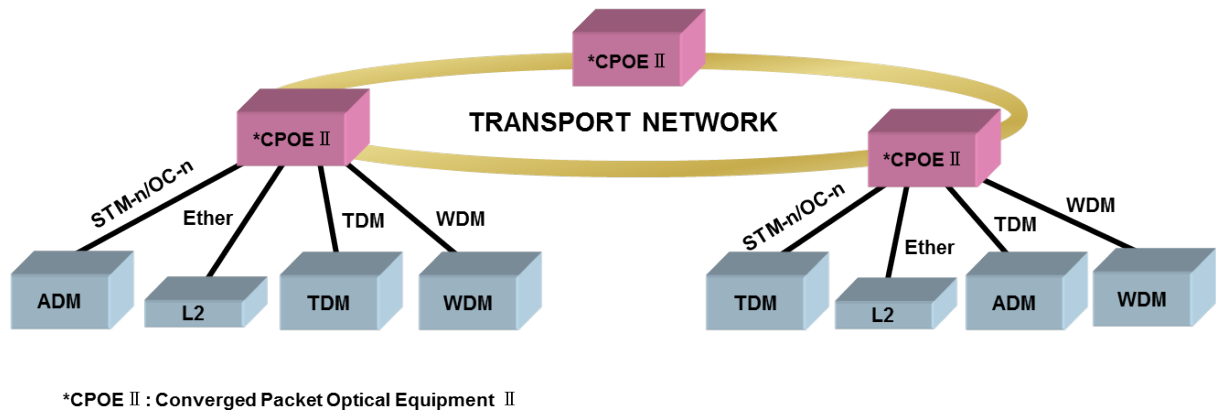

(6) Figure of merit

The figure of merit for converged packet optical equipment shall be the maximum throughput per average power consumption.

The ATIS figure of merit for transport equipment covers single-function equipment, such as WDM-only or TDM-only equipment, and does not indicate figure of merit for converged equipment with multiple function-capacity. However, the figure of merit for converged packet optical equipment for this Guideline shall be the ATIS figure of merit of “maximum throughput per average power consumption.”

The figure of merit (TEER) designated by ATIS for transport equipment is as follows.

$$\begin{aligned} \text{TEER}_{\text{CERT}} &= D_{\text{TEER}} / P_{\text{TEER-CERT}} \\ &= \sum D_i / \{(P_{\text{CERT-0}} + P_{\text{CERT-50}} + P_{\text{CERT-100}}) / 3\} \end{aligned}$$

TEER_{CERT}: Certified TEER measured at a specific configuration

D_{TEER}: Total data rate (bps)

P_{TEER-CERT}: Measured power consumption (W)

D_i: Data rate (bps) at a given interface i

P_{CERT-0}: Measured power consumption (W) at a 0% data traffic utilization

P_{CERT-50}: Measured power consumption (W) at a 50% data traffic utilization

P_{CERT-100}: Measured power consumption (W) at a 100% data traffic utilization

<For converged packet optical equipment (with packet & TDM signal functions)>

For converged packet optical equipment capable of both packet as well as TDM functions, interface cards are added depending on the data usage volume. Therefore, in general,

$$(P_{\text{CERT-0}} + P_{\text{CERT-50}} + P_{\text{CERT-100}}) / 3 \quad \doteq \quad (P_{\text{CERT-0}} + P_{\text{CERT-100}}) / 2$$

Thus, in practice, $TEER_{CERT}$ for converged packet optical equipment (with packet & TDM signal functions) shall be as follows.

$$\begin{aligned} TEER_{CERT} &= D_{TEER} / P_{TEER-CERT} \\ &= \Sigma Di / \{(P_{CERT-0} + P_{CERT-100}) / 2\} \\ &= \text{Maximum throughput/average power consumption} \end{aligned}$$

The average power consumption for converged packet optical equipment (with packet & TDM signal functions)

$$= (P_{idle} + P_{max}) / 2$$

P_{idle} : Power consumption (W) of total equipment with no data throughput with minimum components and path configuration

P_{max} : Power consumption (W) of total equipment during main signal transmission with maximum component configuration

< For converged packet optical equipment (with WDM signal function)>

Converged packet optical equipment with WDM functions generally operate with 100% transport assurance, therefore,

$$\begin{aligned} P_{CERT-0} &= P_{CERT-50} = P_{CERT-100} \text{ and,} \\ (P_{CERT-0} + P_{CERT-50} + P_{CERT-100}) / 3 &\doteq (P_{CERT-0} + P_{CERT-100}) / 2 \end{aligned}$$

Thus, in practice, $TEER_{CERT}$ for converged packet optical equipment with WDM signal function shall be as follows.

$$\begin{aligned} TEER_{CERT} &= D_{TEER} / P_{TEER-CERT} \\ &= \Sigma Di / \{(P_{CERT-0} + P_{CERT-100}) / 2\} \\ &= \text{Maximum throughput/average power consumption} \end{aligned}$$

The average power consumption for converged packet optical equipment (with WDM signal function)

$$= (P_{idle} + P_{max}) / 2$$

P_{idle} : Power consumption (W) at 1 wavelength

P_{max} : Power consumption (W) at full wavelength

Measurement of the average power consumption shall be taken from power consumption when configured for maximum transmission capacity

The maximum throughput shall be the total throughput at full wave length.

<Definition of throughput>

- The traffic pattern of converged packet optical equipment is as follows:

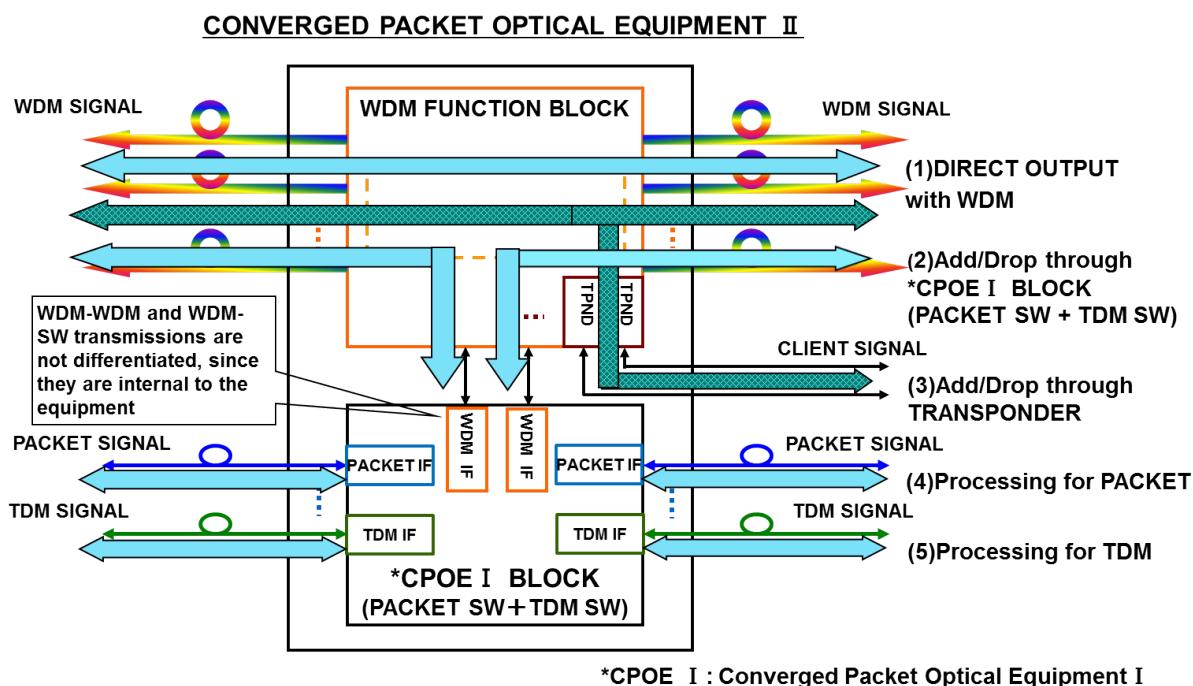

Characteristic traffic of converged packet optical equipment included in throughput calculations

Pathway	Throughput used for calculating figure of merit	Notes
(1) Transmitted as WDM (unchanged)	-	Not included since power consumption of OADM/ROADM/OXC parts are small
(2) Add/Drop from WDM to packet SW/TDM SW	WDM signal (C) throughput \times Add/Drop rate (α)	
(3) Add/Drop from WDM to transponder	-	Not included since not a major function of converged packet optical equipment II
(4) Packet processing part	Packet signal (A) throughput	
(5) TDM processing part	TDM signal (B) throughput	

- A: Maximum throughput of packet function (Gbps)
 $= [\text{Port speed (Gbps)} \times \text{number of ports} \times \text{number of slots}]$
- B: Maximum throughput of TDM function (Gbps)
 $= [\text{Port speed (Gbps)} \times \text{number of ports} \times \text{number of slots}]$
- C: Maximum throughput of WDM function (Gbps)
 $= [\text{Port speed (Gbps)} \times \text{number of ports} \times \text{number of slots}]$
- α : Add/Drop rate of WDM function

In order to maximize use of converged packet optical equipment II features, the equipment shall be configured so that the traffic of WDM signals flowing into the converged packet optical equipment I part is maximized and the conditions of A, B, C

and α are $C \times \alpha = A+B$.

- (1) Maximum throughput of converged packet optical equipment (with packet & TDM & WDM signal functions)

$$\text{Maximum throughput} = \sqrt{\{A^2+B^2+(C \times \alpha)^2\}/3}$$

Furthermore, if packet or TDM functions are not supported, the following shall apply,

- (2) Maximum throughput of converged packet optical equipment (with packet & WDM signal functions)

$$\text{Maximum throughput} = \sqrt{\{A^2+(C \times \alpha)^2\}/2}$$

- (3) Maximum throughput of converged packet optical equipment (with TDM & WDM signal functions)

$$\text{Maximum throughput} = \sqrt{\{B^2+(C \times \alpha)^2\}/2}$$

The figure of merit of converged packet optical equipment with packet & TDM & WDM signal functions shall be as follows:

$$\text{Figure of merit} = \text{Maximum throughput (Gbps)/average power consumption (W)}$$

$$= \sqrt{\{A^2+B^2+(C \times \alpha)^2\}/3} / \{(P_{\text{idle}} + P_{\text{max}})/2\}$$

P_{idle} : Power consumption (W) of total equipment with no data throughput with minimum components and path configuration (WDM part: 1 wave length, maximum frequency (ex: 1 wave×100 Gbps))

P_{max} : Power consumption (W) of total equipment during main signal transmission with maximum component configuration (WDM part: full wave length, maximum frequency (ex: 80 wave×100 Gbps))

α : WDM Add/Drop rate

The Add/Drop rate will change with operation status, but since there is no actual operational data, the maximum capacity of the equipment shall aim for $\alpha=1$.

* State of the equipment at maximum throughput.

(7) Normative reference

- [1] Method for determining normative reference

The normative reference for converged packet optical equipment (packet & TDM & WDM functions) shall be values derived by accounting for technological trends to the average metric values based on products shipped in Fiscal Year 2013 (CIAJ survey).

[Normative reference]

<When configured with WDM functional part at $100G \times N$ >

Converged packet optical equipment (packet and WDM functions):

0.1880 (Gbps/W)

[Approximate Date for Achieving Normative References]

End of Fiscal Year 2016

[2] Assessment scale references

Set a threshold using the rate of reduction versus the power consumption at normative reference. In assessment scale, the rank including normative reference shall be ★★.

Reference example 1) Average power consumption at normative reference for equipment with 8,800 Gbps packet function and 8,800 Gbps WDM function.

Assessment scale	Rate of reduction vs. power consumption at NR	Average power consumption (W) with 8,800Gbps packet function and 8,800 Gbps WDM function
★★★★★	$n \geq 30\%$	$P \leq 32,765.95$
★★★★★	$20\% \leq n < 30\%$	$32,765.95 < P \leq 37,446.80$
★★★	$10\% \leq n < 20\%$	$37,446.80 < P \leq 42,127.65$
★★ (includes NR)	$0\% \leq n < 10\%$	$42,127.65 < P \leq 46,808.51$
★	Normative reference not achieved	$P > 46,808.51$

(Note) In power consumption, calculate values to the second decimal place.

Reference example 2) Average power consumption at normative reference for equipment with 8,000 Gbps packet function and 8,000 Gbps WDM function.

Assessment scale	Rate of reduction vs. power consumption at NR	Average power consumption (W) with 8,000 Gbps packet function and 8,000 Gbps WDM function
★★★★★	$n \geq 30\%$	$P \leq 29,787.23$
★★★★★	$20\% \leq n < 30\%$	$29,787.23 < P \leq 34,042.55$
★★★	$10\% \leq n < 20\%$	$34,042.55 < P \leq 38,297.87$
★★ (includes NR)	$0\% \leq n < 10\%$	$38,297.87 < P \leq 42,553.19$
★	Normative reference not achieved	$P > 42,553.19$

(Note) In power consumption, calculate values to the second decimal place.

(8) Measurement Methodology
 [1] Measurement configuration

[Example of maximum component configuration for measuring P_{max}]

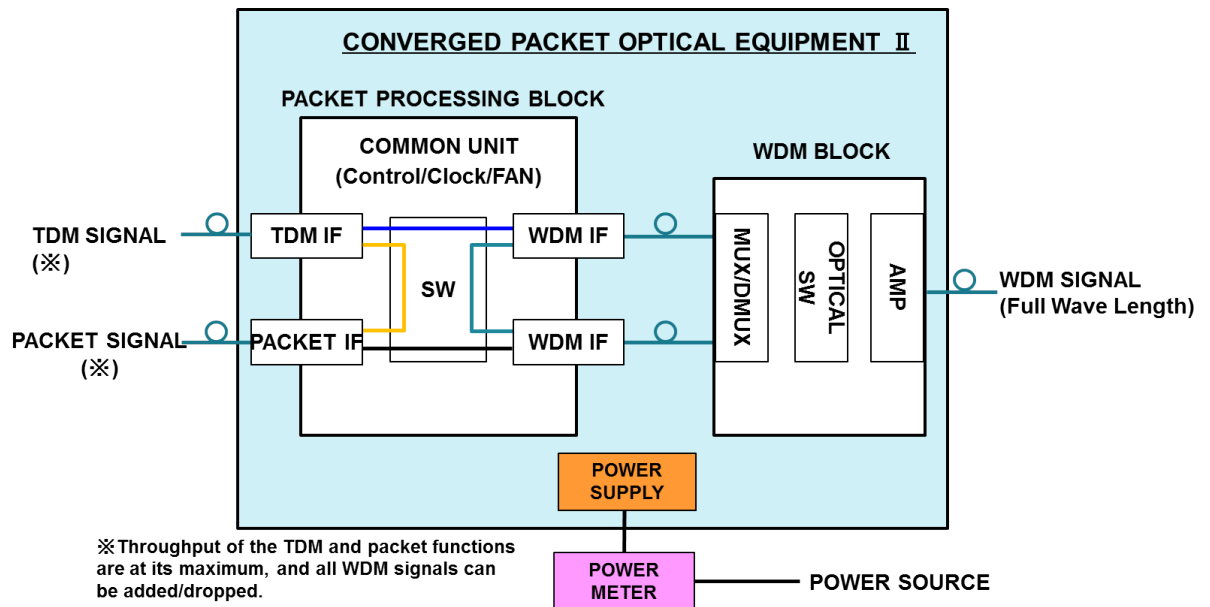

[Example of minimum component and path configuration for measuring P_{idle}]

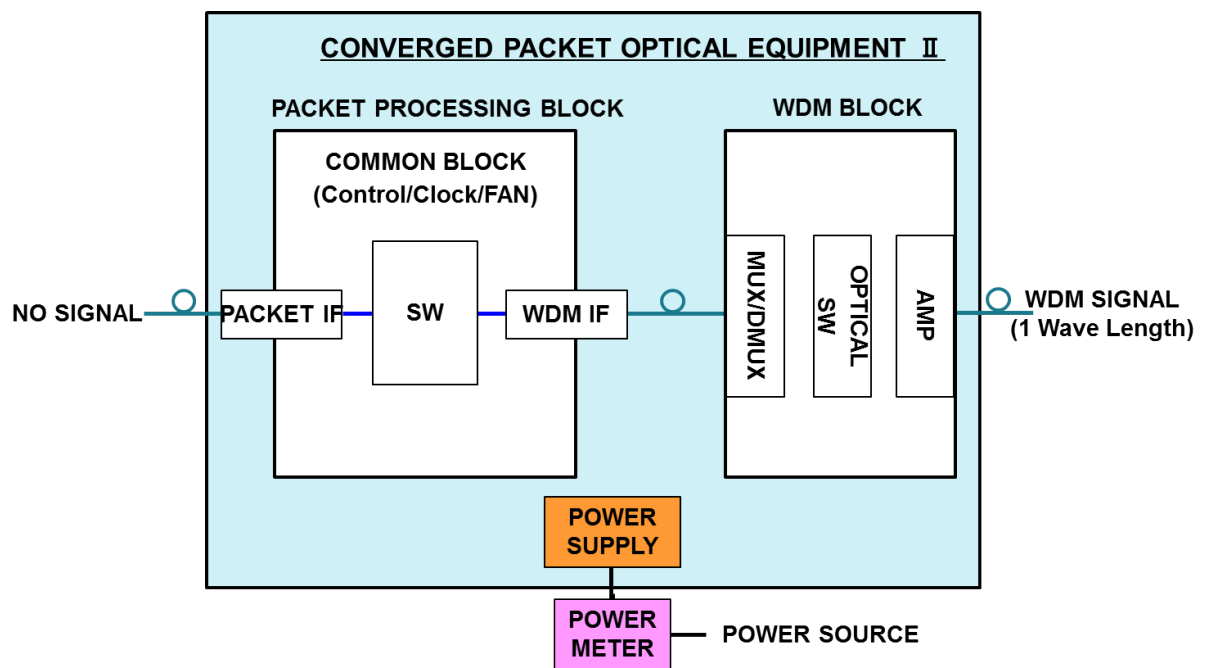

[2] Measurement conditions

(a) Interface

1) Selection of the interface

- Select the interface where the throughput of the WDM part ($C \times \alpha$) is equivalent to the sum of the packet and TDM part throughputs ($A+B$), and as much as possible, WDM signals are Added/Dropped.

2) Function combination patterns

- For the TDM, packet and WDM interfaces, conduct measurements selecting the configurable pattern at NNI/UNI sides from below

[1] WDM (NNI), TDM & packet (UNI)

[2] WDM (NNI), TDM (UNI)

[3] WDM (NNI), packet (UNI)

3) Interface when measuring P_{\max} configuration

- Use the interface selected in 1), and configure using maximum throughput.

4) Interface when measuring P_{idle} configuration

- Use the interface selected in 3), and configure including 1 path with the WDM part.

5) Configuration for redundancy

- There is no specification of interface when configured for redundancy. When configured for redundancy, calculate the figure of merit with the redundant interface as part of the main unit.

(b) Transmission load

1) Transmission load when measuring P_{\max}

- Maximum throughput when configured at maximum capacity

2) Transmission load when measuring P_{idle}

- Non-transmitting state when configured with minimum paths at minimum capacity

(c) Environmental conditions

- Temperature: $25^{\circ}\text{C} \pm 5^{\circ}\text{C}$
- Humidity: not stipulated
- Air pressure: not stipulated

(d) Test voltage

- DC - $48\text{V} \pm 1\text{V}$ or AC $100\text{V} \pm 10\%$ 50/60 Hz

(e) Number of equipment measured

- There is no stipulation on number of equipment to be measured, but if multiple equipment is measured, indicate the average value.

(f) Number of measurements

- There is no stipulation on number of measurements, but if measurements are taken multiple times, indicate the average value.

(g) Measurement precision

- Not stipulated.

(9) Assessment Result and Assessment Scale Ranking

[1] Assessment result

The assessment result shall be the figure of merit actually measured by the vendor according to 5.2.3.2 (8) Measurement Methodology.

[2] Assessment scale ranking

The assessment scale ranking (★-★★★★★) shall be based on normative reference and assessment result.

[3] Variance in assessment result

Permissible variance due to differences in equipment (units) shall be determined in the future.

The average of the actual measurement values for the figure of merit attained by the vendor shall be submitted as the assessment result.

5.2.4 PON Equipment

5.2.4.1. GE-PON Equipment

(1) Equipment Definition

[Common Items]

Ethernet PON equipment in compliance with or an extension of IEEE802.3ah, providing a maximum transmission rate of 1 Gbps.

OLT (Note 1)

- Power source specifications (AC or DC)
- No line concentrator functions (Note 2)

ONU (Note 3)

- Power source specifications (AC) (Note 4)
- Standalone functions only. Compound functions not included. (Note 5)
- UNI type (100 Mbps or 1 Gbps)

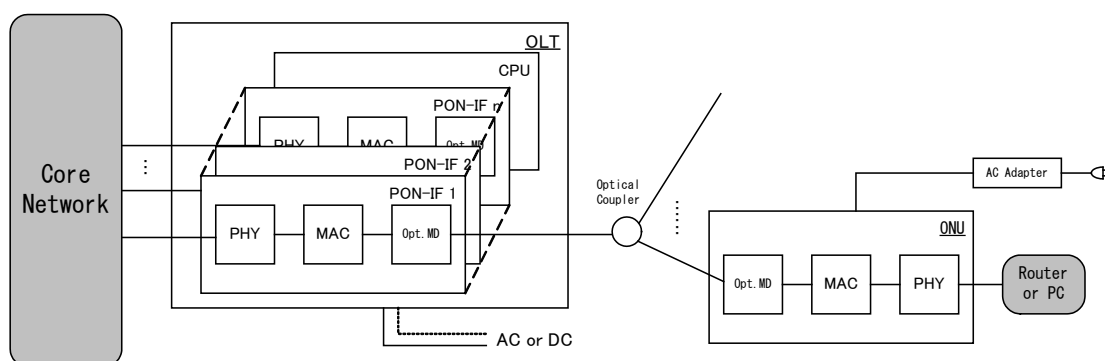

Notes

1: NNI I/F and the number of ports not stipulated. QoS and functions such as priority control not stipulated. Number of branches also not stipulated.

- 2: The scope of this Guideline covers OLT for the domestic carrier market only. If the OLT has functions other than PON (such as line concentrator functions), disable those functions before taking measurements.
- 3: UNI I/F and the number of ports not stipulated. QoS and functions such as priority control not stipulated.
- 4: The scope of this Guideline covers ONU for the domestic consumer market only. AC adapter power supply is standard for ONU domestic consumer market.
- 5: If the ONU has multiple functions, disable those functions before taking measurements.

(2) Figures of merit

- For OLT, use a value that divides average power consumption for the OLT (at full mounting), measured using DC input if the product power source is DC and AC input if the power source is AC, by the total number of lines (Total number of IF ports × number of PON branches).

OLT figure of merit: $E = \text{average power consumption (W)} / \text{total number of lines}$

- For ONU, use ONU average power consumption measured on the supply side of the AC adapter.

ONU figure of merit: $P = \text{average power consumption (W)}$

Note:

Average power consumption = (power consumption at 100% load + power consumption at 50% load + power consumption at 0% load) / 3
Total number of lines = total number of IF ports × 32

(3) Normative References

[1] Method for determining normative references

Normative references for OLT and ONU equipment shall be values derived by accounting for technological trends to the average metric values based on products shipped in Fiscal Year 2013 (CIAJ survey).

[Normative References]

OLT: 0.40 W (AC) or 0.34 W (DC)

ONU: 2.84 W (100Mbps) or 3.75 W (1Gbps)

[Approximate Date for Achieving Normative References]

End of Fiscal Year 2016

[2] Assessment scale references

Set a threshold using the rate of reduction versus the power consumption at normative reference. In assessment scale, the rank including normative reference shall be ★★.

Average power consumption for OLT normative references: 0.40 W (AC power

supply) or 0.34 W (DC power supply)

Average power consumption for ONU normative references: 2.84 W (100 Mbps) or 3.75 W (1 Gbps).

OLT Power Consumption Values

Assessment scale	Rate of reduction vs. power consumption at NR	Average power consumption for OLT (AC power source) (W)	Average power consumption for OLT (DC power source) (W)
★★★★★	$n \geq 30\%$	$E \leq 0.280$	$E \leq 0.238$
★★★★	$20\% \leq n < 30\%$	$0.280 < E \leq 0.320$	$0.238W < E \leq 0.272$
★★★	$10\% \leq n < 20\%$	$0.320 < E \leq 0.360$	$0.272W < E \leq 0.306$
★★ (includes NR)	$0\% \leq n < 10\%$	$0.360 < E \leq 0.400$	$0.306W < E \leq 0.340$
★	Normative reference not achieved	$E > 0.400$	$E > 0.340$

(Note) In power consumption, calculate values to the third decimal place.

ONU Power Consumption Values

Assessment scale	Rate of reduction vs. power consumption at NR	Average power consumption for ONU (100 Mbps)	Average power consumption for ONU (1 Gbps)
★★★★★	$n \geq 30\%$	$P \leq 1.988$	$P \leq 2.625$
★★★★	$20\% \leq n < 30\%$	$1.988 < P \leq 2.272$	$2.625 < P \leq 3.000$
★★★	$10\% \leq n < 20\%$	$2.272 < P \leq 2.556$	$3.000 < P \leq 3.375$
★★ (includes NR)	$0\% \leq n < 10\%$	$2.556 < P \leq 2.840$	$3.375 < P \leq 3.750$
★	Normative reference not achieved	$P > 2.840$	$P > 3.750$

(Note) In power consumption, calculate values to the third decimal place.

(4) Measurement Methodology

[1] Measurement configuration

[OLT]

For OLT, use 1 Gbps for both the NNI side and the PON side and use the following three settings for load factor. Furthermore, in stipulating load factor, the load factor specified by data entry side shall be used (NNI or UNI).

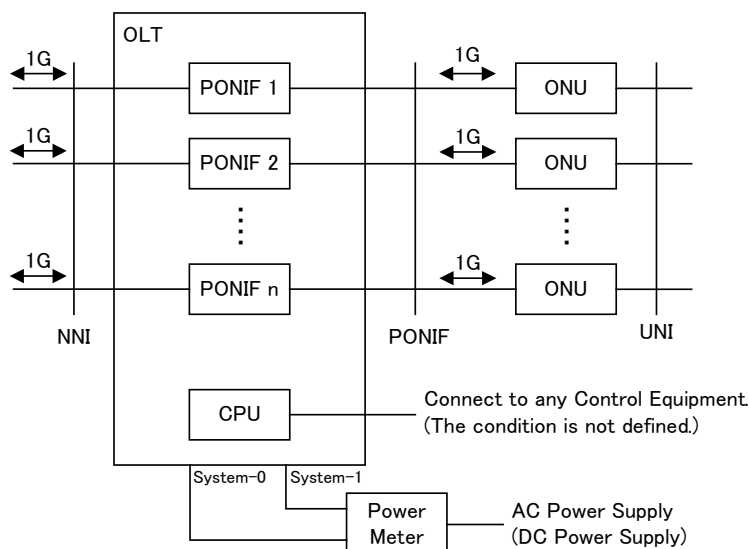

100% load factor: a state where 64 byte frames flow continuously (without interruption).

50% load factor: the state where 512 byte frames flow 50%.

0% load factor: the state where frames are not flowing.

[ONU]

For ONU, carry out measurements using configurations (a) and (b). As in the case of OLT, apply three load factor settings.

(a) 1 Gbps on PON side, 1 Gbps on UNI side

(b) 100 Mbps on PON side, 100 Mbps on UNI side

Furthermore, in stipulating load factor, as in the case of OLT, it shall be acceptable to use the load factor specified by data entry sites (NNI or UNI).

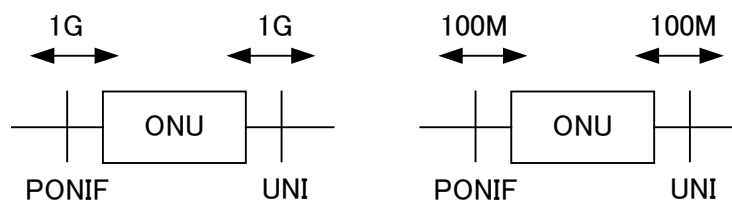

[2] Measurement conditions

(a) Temperature: room temperature (around $25^{\circ}\text{C} \pm 5^{\circ}\text{C}$)

(b) Humidity: no stipulation

(c) Air pressure: no stipulation

(d) Power supply conditions:

Using AC voltage: AC $100\text{ V} \pm 10\%$ ($50/60\text{Hz} \pm 1\%$)

Using DC voltage: DC $-48 \pm 1\text{ V}$

(5) Assessment Result and Assessment Scale Ranking

[1] Assessment result

The assessment result shall be the figure of merit actually measured by the vendor according to 5.2.4.1(4) Measurement Methodology.

- [2] Assessment scale ranking
The assessment scale ranking (★-★★★★★) shall be based on normative reference and assessment result.
- [3] Variance in assessment result
Permissible variance due to differences in equipment (units) shall be determined in the future.
The average of the actual measurement values for the figure of merit attained by the vendor shall be submitted as the assessment result.

5.2.5 Broadband Base Station Equipment

5.2.5.1. WiMAX™ Base Station Equipment

(1) Equipment Definition

- Mobile WiMAX base station equipment in compliance with IEEE802.16e.
- Applies to BS (Base Station, WiMAX base station) only and does not include MS (Mobile Station, WiMAX subscriber device) and higher end core network equipment.
- BS equipment takes the following three configurations.
 - [1] RF (radio frequency) and BB (baseband) separate-type.
 - [2] RF and BB integrated.
 - [3] RF and BB integrated with ASN-GW (Access Service Network Gateway).

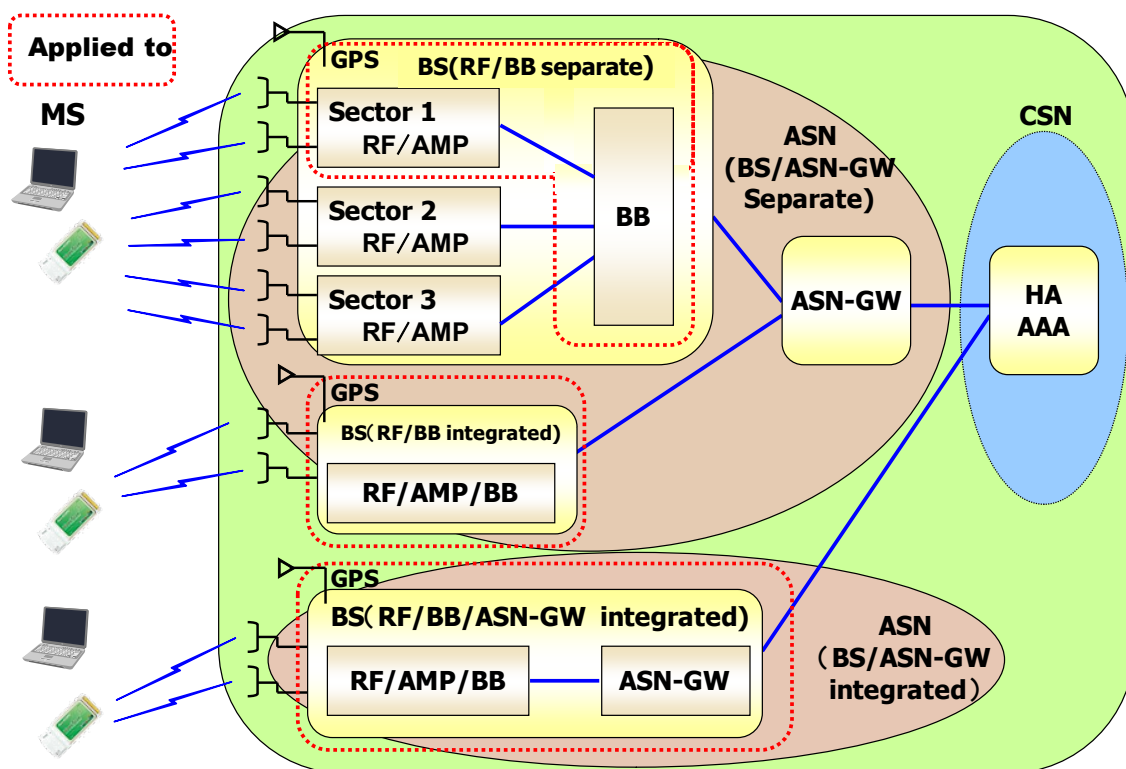

Notes

AAA: Authentication, Authorization, and Accounting;
 AMP: Amplifier; ANT: Antenna;
 ASN: Access Service Network; ASN-GW: Access Service Network Gateway;
 BB: Base Band; BS: Base Station, WiMAX base station;
 CSN: Connectivity Service Network;
 GPS: Global Positioning System
 HA: Home Agent;
 MS: Mobile Station, WiMAX subscriber device ;
 RF: Radio Frequency

[Common Equipment Specifications and Equipment Configurations]

Equipment specifications/ configuration	Item	Specifications
Equipment specifications	Frequency band	2,595MHz - 2,625MHz or 2,582MHz - 2,592MHz
	Signal bandwidth	10MHz
	Duplex operation	TDD
	Wireless access system / modulation system	SOFDMA/QPSK, 16QAM, 64QAM (※) ※64QAM is down link only
	FFT size	1024
	UL/DL frame ratio	DL/UL : (29:18)
	Segmentation	None
	Inter-base station synchronization system	GPS
Equipment configuration	Antenna configuration	MIMO Matrix-A or Matrix-B(2TX+2RX)

Notes:

SOFDMA: Scalable Orthogonal Frequency Division Multiple Access;
 DL: Down Link; UL: Up Link;
 QAM: Quadrature Amplitude Modulation;
 QPSK: Quadrature Phase Shift Keying;
 FFT: Fast Fourier Transform;
 MIMO: Multiple Input Multiple Output;
 FFT: Fast Fourier Transform

[Categorized Equipment Specifications and Equipment Configurations]

Equipment specifications / configuration	Item	Classification specification
Equipment specifications	RF output power	① 10W+10W ② 5W+5W
	Primary power supply	① AC ② DC
	Network interface	① Number of optical ports: N

		② Number of electrical ports: M
	Transmission carrier count	① 1 ② 2 ③ 3
	Baseband processor	① single (1) ② dual (2)
Equipment configuration	RF/BB configuration	① Integrated ② Separate

The above items may be combined independent of each other. Of those combinations, the following three types, which are currently commercialized and thus measurable, are subject to this guideline.

Name	Integrated 10W equipment (1 BB system)	Integrated 10W equipment (2 BB systems)	Integrated 5W equipment (1 BB system)
Output power	10W+10W	10W+10W	5W+5W
Baseband processor	1 system	2 systems	1 system
RF/BB configuration	Integrated	Integrated	Integrated
Supply side power source input	AC	AC	AC

(2) Figures of merit

- Figure of merit for WiMAX base station equipment shall be the sum of RF output divided by the average primary supply-side power.

$$\text{Figure of merit } E = \sum P_n / \{P_{\text{idle}} \times (1-\alpha) + P_{\text{max}} \times \alpha\}$$

P_n : RF output power at antenna connector n (W)

P_{idle} : primary supply-side power when transmitting only the Preamble and MAP.

P_{max} : primary supply-side power at maximum transmission (W). The state where all down link symbols are being transmitted based on an MS connection or the test settings.

α : average of daily down link transmission traffic rate. Average daily traffic rate using down link Data Symbol, excluding Preambles and MAP.

<For WiMAX Two Antenna Base Station Equipment>

Since the daily average down link traffic is not available, calculate with $\alpha = 0.5$ for the time being.

$$\text{Figure of merit} = (P_{\text{out1}} + P_{\text{out2}}) / \{(P_{\text{idle}} + P_{\text{max}})/2\}$$

P_{out1} : RF output power at antenna connector # 1 (W)

P_{out2} : RF output power at antenna connector # 2 (W)

P_{idle} : primary supply-side input power under idle mode (W)

P_{max} : primary supply-side input power during maximum transmission (W)

(3) Normative References

[1] Method for determining normative references

Normative references for the three types of WiMAX base station equipment stipulated above, namely, an integrated 10 W equipment (one system), integrated 10 W equipment (two systems), and integrated 5W equipment (one system) shall be values derived by accounting for technological trends to the average metric values based on current products (CIAJ survey).

[Normative References]

Integrated 10 W equipment (one system): 12.60

Integrated 10 W equipment (two systems): 9.63

Integrated 5W equipment (one system): 5.84

[Approximate Date for Achieving Normative References]

End of Fiscal Year 2012

[2] Assessment scale references

Set a threshold using the rate of reduction versus the power consumption at normative reference. In assessment scale, the rank including normative reference shall be ★★.

Average power consumption for normative reference of integrated 10 W equipment (one system): 158.7 W

Average power consumption for normative reference of integrated 10 W equipment (two systems): 207.7 W

Average power consumption for normative reference of integrated 5 W equipment (one system): 171.2 W

Assessment scale	Rate of reduction vs. power consumption at NR	Average power consumption normative reference for integrated 10W equipment (1BB) (W) (Note 1)	Average power consumption normative reference for integrated 10W equipment (2BB) (W) (Note 1)
★★★★★	$n \geq 30\%$	$P \leq 111.09$	$P \leq 145.39$
★★★★	$20\% \leq n < 30\%$	$111.09 < P \leq 126.96$	$145.39 < P \leq 166.16$
★★★	$10\% \leq n < 20\%$	$126.96 < P \leq 142.83$	$166.16 < P \leq 186.93$
★★ (includes NR)	$0\% \leq n < 10\%$	$142.83 < P \leq 158.70$	$186.93 < P \leq 207.70$

★	Normative reference not achieved	P > 158.70	P > 207.70
---	----------------------------------	------------	------------

(Note) In power consumption, calculate values to the second decimal place.

Assessment scale	Rate of reduction vs. power consumption at NR	Average power consumption normative reference for integrated 5W equipment (1BB) (W) (Note 2)	
★★★★★	$n \geq 30\%$	$P \leq 119.86$	
★★★★	$20\% \leq n < 30\%$	$119.86 < P \leq 136.99$	
★★★	$10\% \leq n < 20\%$	$136.99 < P \leq 154.11$	
★★ (includes NR)	$0\% \leq n < 10\%$	$154.11 < P \leq 171.20$	
★	Normative reference not achieved	$P > 171.20$	

(Note) In power consumption, calculate values to the second decimal place.

Notes

- 1: When RF output power at antenna connectors are 10.0 W X 2
- 2: When RF output power at antenna connectors are 5.0 W X 2

(4) Measurement Methodology

[1] Measurement configuration

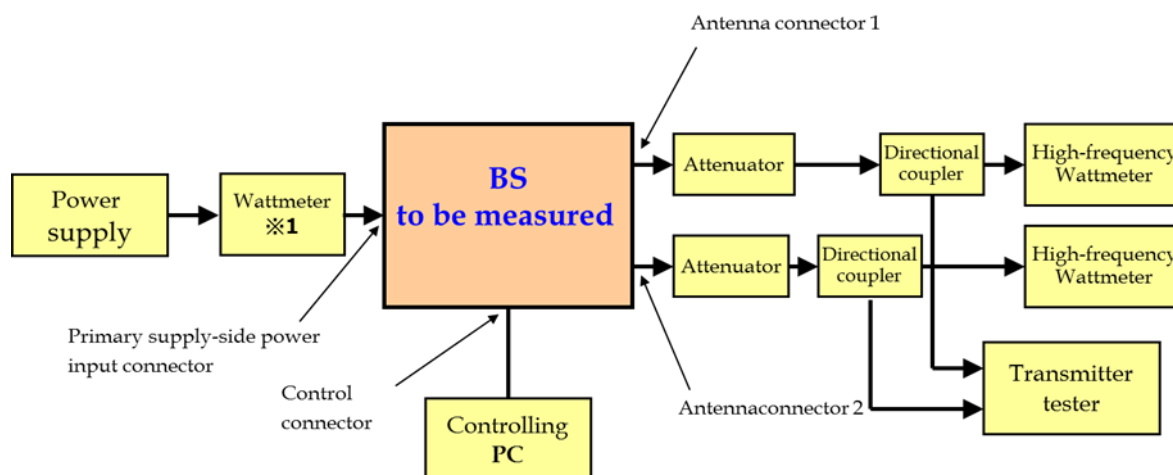

※1 An ammeter or voltmeter may be used in place of a wattmeter

[2] Measurement conditions

[Environment and Electrical Conditions]

Item	Conditions	Notes
Environment conditions	Room temperature $+25^{\circ}\text{C} \pm 5^{\circ}\text{C}$	
Primary power	AC Designated voltage $\pm 1\%$	50Hz or 60Hz

supply voltage	DC	Designated voltage $\pm 0.5\%$	
Operating conditions	10W \times 2ANT	<ul style="list-style-type: none"> • Designated power no more than +12.2% (+0.5dB) • Measure up to one decimal point 	Measure transmission power using TELEC-T137 measurement method for antenna power.
	5W \times 2ANT		

[Non-Environmental and Electrical Conditions]

- (a) The number of units of BS equipment or AMP to be measured shall not be stipulated, but if multiple units are measured, the average figure shall be used.
- (b) This guideline does not stipulate the number of times measurements shall be taken for each item in relation to a BS or AMP. However, use an average value when measuring multiple times.
- (c) Measure the following functions after having provided continuous power supply to the equipment.
 - Upstream receiving circuit, line interface, GPS circuit
- (d) Begin measurements after the equipment has been exposed to room temperature for one or more hours with the power on.

[Measurement methodology]

Item		Measurement method	
Primary supply side power at maximum RF output	P_{max}	Use an MS connection or test settings where all down link symbols are being transmitted.	<ul style="list-style-type: none"> • Measure using a wattmeter. • Use effective power consumption of the equipment when input is AC. • Acceptable to use Ampere meter/voltmeter when input is DC.
Primary supply-side input power under idle mode	P_{idle}	Configure so only down link preamble and MAP are being transmitted. (Data is PUSC)	

(5) Assessment Result and Assessment Scale Ranking

[1] Assessment result

The assessment result shall be the figure of merit actually measured by the vendor according to 5.2.5.1(4) Measurement Methodology.

[2] Assessment scale ranking

The assessment scale ranking (★-★★★★★) shall be based on normative reference and assessment result.

[3] Variance in assessment result

Permissible variance due to differences in equipment (units) shall be determined in the future.

5.2.5.2. LTE Base Station Equipment

(1) Equipment Definition

- An LTE/E-UTRAN base station (eNodeB) that complies with 3GPP standards.
- Comprises of eNodeB control units and radio units. Does not include maintenance tools, external power sources, rectifiers, remote tilt controller or the like.
- Scope applies to the following implemented configurations

Name	Segregated 20W Device	Integrated 20W Device	Segregated 10W Device
Output power per sector	20W + 20W	20W + 20W	10W + 10W
Radio unit and control unit configuration	Segregated	Integrated	Segregated

Note:

Segregated: Radio unit and control unit are driven by separate power sources.

Integrated: Radio unit and control unit are driven by the same power source.

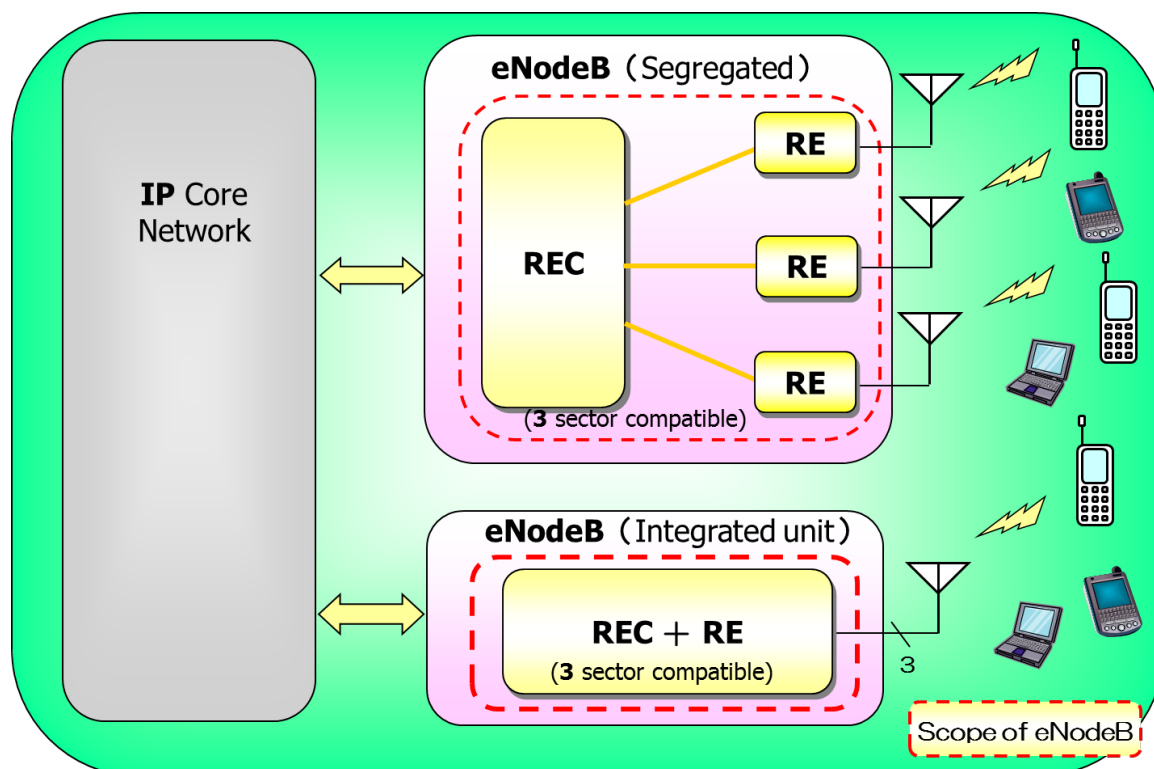

Note:

3GPP: 3rd Generation Partnership Project

LTE: Long Term Evolution

E-UTRAN: Evolved UMTS Terrestrial Radio Access Network

eNodeB: evolved Node B REC: Radio Equipment Control RE: Radio Equipment

【Common Equipment Specifications】

Item	Specifications	Notes
Frequency band	(Not specified)	For reference, provide frequency band information when submitting measurement data.
Signal bandwidth	10MHz	Measurement conditions
Number of carriers	1 Carrier	
Number of sectors	3	
Number of antennas	Transmit: 2 Receive: 2 (space diversity)	MIMO
Radio access method	Transmit: OFDMA Receive: SC-FDMA	
Multiplexing method	FDD	
Modulation method	Transmit: QPSK, 16QAM, 64QAM Receive: QPSK, 16QAM	
S1 interface	Gigabit Ethernet x n	n:1 or more
Primary Power supply input	DC -48V	
Redundancy configuration	Not applicable	

MIMO:Multiple Input Multiple Output

OFDMA: Orthogonal Frequency Division Multiple Access

SC-FDMA: Single Carrier-Frequency Division Multiple Access

FDD: Frequency Duplex Division

QPSK: Quadrature Phase Shift Keying

16QAM:16 Quadrature Amplitude Modulation

64QAM:64 Quadrature Amplitude Modulation

(2) Figures of Merit

- LTE base station equipment figure of merit shall be a value that is the total transmission output divided by the average supply side power input.

$$\text{Figure of Merit: } E = \sum P_n / [P_{\text{idle}} \times (1 - \alpha) + P_{\text{max}} \times \alpha]$$

P_n : Transmitted power (W) of antenna connector n

P_{idle} : Primary supply-side input power (W) when there is no load, with the traffic resource block removed from E-TM1.1 of 3GPP TS36.141. Furthermore, operation conditions with no traffic (but with broadcast information) shall be permissible.

P_{max} : Primary supply-side input power (W) during maximum transmission, 3GPP TS36.141 E-TM1.1 transmission state

α : Daily average transmission traffic rate

<LTE Two Antenna Base Station Equipment>

Calculate using $\alpha=0.5$ due to lack of available operating data.

$$\text{Figure of Merit: } E = (P_{\text{out1}} + P_{\text{out2}}) / \lceil (P_{\text{idle}} + P_{\text{max}}) / 2 \rceil$$

P_{out1} : Transmission power (W) from antenna connector 1

P_{out2} : Transmission power (W) from antenna connector 2

P_{idle} : Primary supply-side input power (W) when there is no load

P_{max} : Primary supply-side input power (W) during maximum transmission

(3) Normative References

[1] Method for determining normative references

Normative references for the abovementioned three types of LTE base station equipment (Segregated 20W Device, Integrated 20W Device, Segregated 10W Device) shall reflect improvements upon average values for current products (per CIAJ) based on technical trends.

【Normative References】

Segregated 20W Device: 20.32(%)

Integrated 20W Device: 13.77(%)

Segregated 10W Device: 6.91(%)

<Reference> Informative value of 6 sectors type

Segregated 20W Device: 21.04(%)

Integrated 20W Device: 16.67(%)

Segregated 10W Device: 8.37(%)

【Approximate Date for Achieving Normative References】

End of Fiscal Year 2013

[2] Assessment scale references

Set a threshold using the rate of reduction versus the power consumption at normative reference. In assessment scale, the rank including normative reference shall be ★★.

Average power consumption for normative reference for segregated 20W equipment: 590.55W

Average power consumption for normative reference for integrated 20W equipment: 871.46W

Average power consumption for normative reference for segregated 10W equipment: 868.31W

Assessment Scale	Rate of reduction vs. power consumption at NR	Average power consumption normative reference (W) for	Average power consumption normative reference (W) for
------------------	---	---	---

		segregated 20W equipment (Note 1)	integrated 20W equipment (Note 1)
★★★★★	$n \geq 30\%$	$P \leq 413.38$	$P \leq 610.02$
★★★★	$20\% \leq n < 30\%$	$413.38 < P \leq 472.44$	$610.02 < P \leq 697.16$
★★★	$10\% \leq n < 20\%$	$472.44 < P \leq 531.49$	$697.16 < P \leq 784.31$
★★ (include NR)	$0\% \leq n < 10\%$	$531.49 < P \leq 590.55$	$784.31 < P \leq 871.46$
★	Normative reference not achieved	$P > 590.55$	$P > 871.46$

Assessment Scale	Rate of reduction vs. power consumption at NR	Average power consumption normative reference (W) for segregated 10W equipment (Note 2)	
★★★★★	$n \geq 30\%$	$P \leq 607.81$	
★★★★	$20\% \leq n < 30\%$	$607.81 < P \leq 694.64$	
★★★	$10\% \leq n < 20\%$	$694.64 < P \leq 781.47$	
★★ (include NR)	$0\% \leq n < 10\%$	$781.47 < P \leq 868.31$	
★	Normative reference not achieved	$P > 868.31$	

(Note) In power consumption, calculate values to the second decimal place.

Notes

- 1: When transmission output power is $20\text{ W} \times 2$
- 2: When transmission output power is $10\text{ W} \times 2$

(4) Measurement Methodology

[1] Measurement configuration

【Integrated】

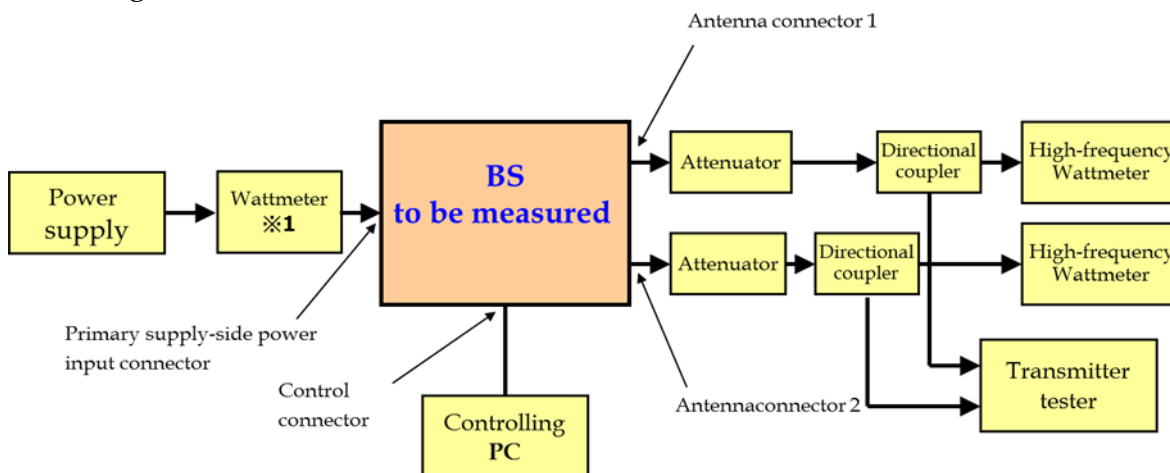

※1 An ammeter or voltmeter may be used in place of a wattmeter

【Segregated】

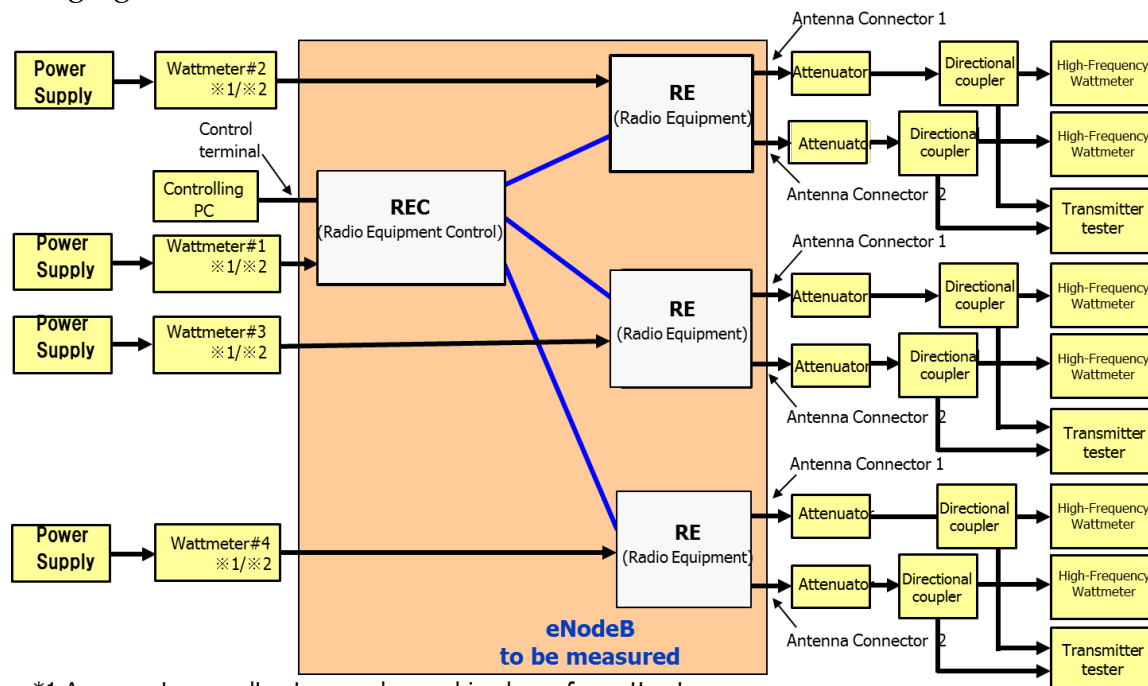

*1 An ammeter or voltmeter may be used in place of a wattmeter.
 *2 The eNodeB power consumption is the sum of wattmeters #1 through #4.

[2] Measurement conditions

【Environment and Electrical Conditions】

Item		Condition	Notes
Environment conditions	Room temperature	+25°C±5°C	
Primary supply-side input power voltage	DC	DC -48V ± 1%	
Operating conditions	20W×2ANT	•No more than Designated power +12.2% (+0.5dB) •Measure up to one decimal point	Measure transmission power using TELEC-T137 measurement method for antenna power.
	10W ×2ANT		

【Non-Environmental and Electrical Conditions】

- (a) This guideline does not stipulate the number of units of eNodeB equipment to be measured. However, use an average value when measuring multiple units.
- (b) This guideline does not stipulate the number of times measurements shall be taken for each item in relation to an eNodeB equipment. However, use an average value when measuring multiple times.
- (c) The following functions are necessary functions for an eNodeB and the measurement shall be conducted when continuous power is supplied to these functions.
 - Upstream receiving current, line interface, (S1/X2 interface), RRC processor,

MAC processor, RLC processor, and PDCP processor.

- (d) Begin measurements after the equipment has been exposed to room temperature for one or more hours with the power on.

MAC: Medium Access Control, PDCP: Packet Data Convergence Protocol,
RLC: Radio Link Control, RRC: Radio Resource Control

【Measurement Methodology】

Item		Measurement method	
Primary supply-side input power at maximum transmission power	Pmax	Set to 3GPP TS36.141 E-TM1.1 transmission state.	Measure using a wattmeter. (Using an ammeter or voltmeter is acceptable.)
Primary supply-side input power when there is no load	Pidle	Set to 3GPP TS36.141 E-TM1.1 transmission state without the traffic resource blocks. Furthermore, operational conditions with no traffic (but with broadcast information) shall be permissible.	

(5) Assessment Result and Assessment Scale Ranking

[1] Assessment result

The assessment result shall be the figure of merit actually measured by the vendor according to 5.2.5.2(4) Measurement Methodology.

[2] Assessment scale ranking

The assessment scale ranking (★-★★★★★) shall be based on normative reference and assessment result in 5.2.5.2(5) [1].

[3] Variance in assessment result

Permissible variance due to differences in equipment (units) shall be determined in the future.

5.2.5.3 3G/LTE Multi-Radio Base Station Equipment

(1) Equipment Definition

- Single 3GPP-standard compliant radio base station equipment which can handle both “3G radio (W-CDMA)” and “LTE radio formats.”
- This equipment shall be composed of radio equipment (RE) and radio equipment control (REC) and shall not include external devices such as maintenance tools, external power supply, rectifiers and remote tilt control device.
- The following table shall define the components and scope of this equipment.

Name	10 MHz (LTE+3G)
Composition Power/Sector	Segregated type 10W 10W+10W
Number of sectors	LTE: 1 sector 3G: 1 sector
Channel bandwidth/Carrier	LTE: 5MHz/1 Carrier 3G: 5MHz/1 Carrier

Note) Segregated type: the RE and REC are in separate locations and each run by their own independent power supply.

3GPP: 3rd Generation Partnership Project

LTE: Long Term Evolution

REC: Radio Equipment Control

RE: Radio Equipment

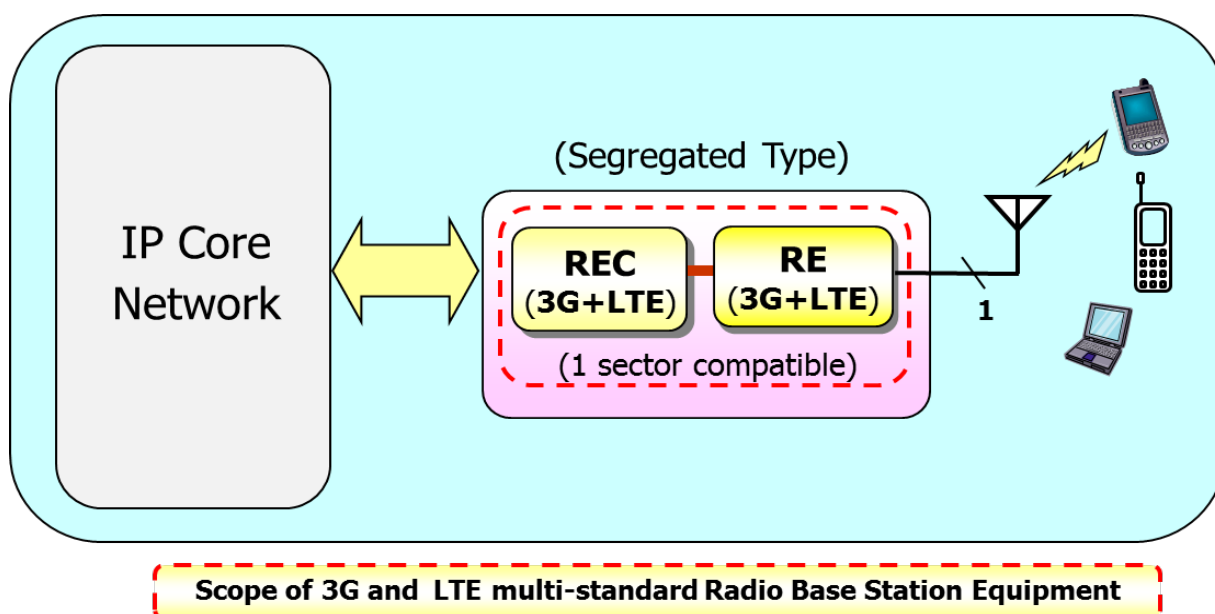

Scope of 3G and LTE multi-standard Radio Base Station Equipment

REC: Radio Equipment Control RE: Radio Equipment

[Common Equipment Specifications]

Item	LTE functional part	3G functional part
Frequency bandwidth	Not specified	
Channel bandwidth	See previous table	
Number of carriers	See previous table	
Number of sectors	1	1
Number of transmitters/receivers	Transmitters: 2 Receivers: 2	Transmitters: 2 Receivers: 2
Radio access format	Transmitters: OFDMA Receivers: SC-FDMA	Transmitters: W-CDMA Receivers: W-CDMA
Multiplexing format	FDD	
Modulation format	Transmitters: QPSK, 16 QAM, 64 QAM	Transmitters: QPSK, 16 QAM

	Receivers: QPSK, 16 QAM	Receivers: QPSK
Line interface (S1/X2 interface or Iub interface)	Gigabit Ethernet x n (n ≥ 1)	
Primary power supply	DC-48V	
Redundancy	None	

OFDMA : Orthogonal Frequency Division Multiple Access

SC-FDMA : Single Carrier-Frequency Division Multiple Access

QPSK: Quadrature Phase Shift Keying

16QAM: 16 Quadrature Amplitude Modulation

64QAM: 64 Quadrature Amplitude Modulation

W-CDMA: Wideband Code Division Multiple Access

(2) Figures of Merit

- 3G/LTE multi-radio base station equipment figure of merit shall be a value that is the total transmission output divided by the average supply side power input.

$$\text{Figure of Merit: } E = \sum P_n / \{P_{\text{idle}} \times (1 - \alpha) + P_{\text{max}} \times \alpha\}$$

P_n : Transmitted power (W) of antenna connector n

P_{idle} : Primary supply-side input power (W) when there is no load

P_{max} : Primary supply-side input power (W) during maximum transmission

α : Daily average transmission traffic rate

<3G/LTE Multi-Radio Base Station Equipment>

Calculate using $\alpha = 0.5$ due to lack of actual performance data.

[Transmission power of 3G 2 antennas base station equipment]

$$P_{3G \text{ out}}: P_{3G \text{ out1}} + P_{3G \text{ out2}}$$

$P_{3G \text{ out1}}$: Transmission power (W) from antenna connector 1

$P_{3G \text{ out2}}$: Transmission power (W) from antenna connector 2

[Transmission power of LTE 2 antennas base station equipment]

$$P_{\text{LTE out}}: P_{\text{LTE out1}} + P_{\text{LTE out2}}$$

$P_{\text{LTE out1}}$: Transmission power (W) from antenna connector 1

$P_{\text{LTE out2}}$: Transmission power (W) from antenna connector 2

[Average input power of entire equipment]

$$P_{\text{in}} = (P_{\text{idle}} + P_{\text{max}}) / 2$$

P_{idle} : Primary supply-side input power (W) when there is no load

P_{max} : Primary supply-side input power (W) during maximum transmission

$$\text{Figure of Merit: } E = (P_{3G \text{ out}} + P_{\text{LTE out}}) / \{(P_{\text{idle}} + P_{\text{max}}) / 2\}$$

[Definition of P_{idle} , P_{max}]

- P_{idle} , P_{max} shall be defined as the primary supply-side input power under the following conditions.
- P_{idle} , P_{max} shall be measured when both 3G and LTE are simultaneously transmitting.

	3G (W-CDMA)	LTE
P_{idle}	3GPP TS25.141 test model 4 transmission state	3GPP TS36.141 E-TM1.1 state, but without traffic resource blocking. Operational state without traffic (with broadcast information) shall be possible.
P_{max}	3GPP TS25.141 test model 1 transmission state	3GPP TS36.141 E-TM1.1 transmission state

(3) Normative References

[1] Method for determining normative references

Normative references for 3G/LTE multi-radio base station equipment shall be an enhanced value based on average values for products shipped in FY2012 (CIAJ survey) accounting for technical trends.

【Normative References】

Segregated Type 10W Equipment: 5.90 (%)

【Approximate Date for Achieving Normative References】

End of Fiscal Year 2015

[2] Assessment scale references

Set a threshold using the rate of reduction versus the power consumption at normative reference. In assessment scale, the rank including normative reference shall be ★★.

Average power consumption for normative reference for segregated type 10W equipment: 338.98W

Assessment Scale	Rate of reduction vs. power consumption at NR	Average power consumption normative reference (W) for segregated 10W equipment (Note 1)
★★★★★	$n \geq 30\%$	$P \leq 237.28$
★★★★	$20\% \leq n < 30\%$	$237.28 < P \leq 271.18$
★★★	$10\% \leq n < 20\%$	$271.18 < P \leq 305.08$
★★ (include NR)	$0\% \leq n < 10\%$	$305.08 < P \leq 338.98$
★	Normative reference not achieved	$P > 338.98$

(Note) For power consumption, calculate values to the second decimal place.

(Note 1) When transmission output power is $10\text{ W} \times 2$

(4) Measurement Methodology

[1] Measurement configuration 【Segregated Type】

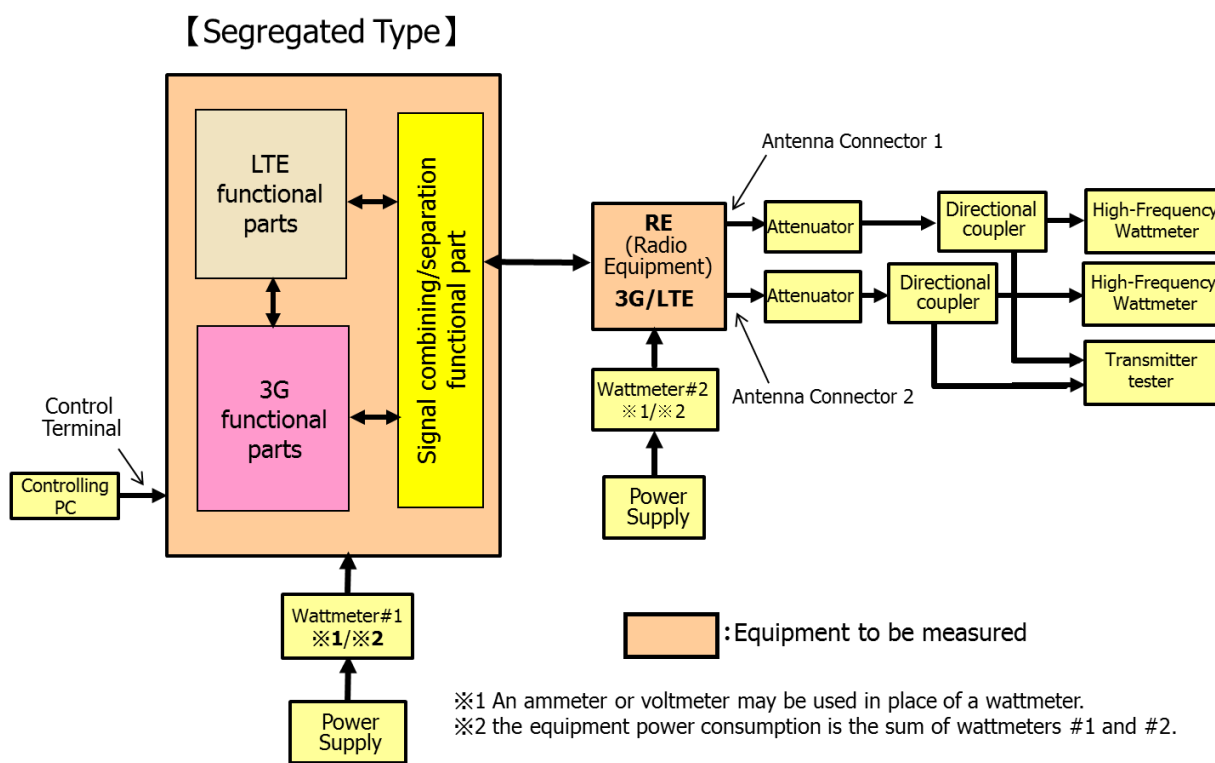

[2] Measurement conditions

【Environment and Electrical Conditions】

Item		Condition	Notes
Environmental conditions	Room temperature	+25°C±5°C	
Primary supply-side input power voltage	DC	DC -48V ± 1%	
Operating conditions	10W ×2ANT (segregated type)	•No more than designated power +12.2% (+0.5dB) •Measure up to one decimal point	Measure transmission power using TELECOM-T137 measurement method for antenna power.

【Non-Environmental and Electrical Conditions】

- (a) This guideline does not stipulate the number of equipment to be measured. However, use an average value when measuring multiple units.
- (b) This guideline does not stipulate the number of times measurements shall be taken for each item. However, use an average value when measuring multiple times.
- (c) Measurement for the following functions shall be conducted with continuous

power supplied to these parts.

- Uplink receiving current, line interface, RRC processing part, MAC processing part, RLC processing part, and PDCP processing part.
- (d) Begin measurements after the equipment has been exposed to room temperature for one or more hours with the power on.

MAC: Medium Access Control, PDCP: Packet Data Convergence Protocol,
 RLC: Radio Link Control, RRC: Radio Resource Control

【Measurement Methodology】

Item		Measurement method	
Primary supply-side input power at maximum transmission power	Pmax	[3G (W-CDMA)] Set to 3GPP TS25.141 test model 1 transmission state [LTE] Set to 3GPP TS36.141 E-TM1.1 transmission state.	Measure using a wattmeter. (Using an ammeter or voltmeter is acceptable.)
Primary supply-side input power when there is no load	Pidle	[3G (W-CDMA)] Set to 3GPP TS25.141 test model 4 transmission state [LTE] Set to 3GPP TS36.141 E-TM1.1 state, but without traffic resource blocking. Operational state without traffic (with broadcast information) shall be possible.	

(5) Assessment Result and Assessment Scale Ranking

[1] Assessment result

The assessment result shall be the figure of merit actually measured by the vendor according to 5.2.5.3 (4) Measurement Methodology.

[2] Assessment scale ranking

The assessment scale ranking (★-★★★★★) shall be based on normative reference and assessment result determined in 5.2.5.3 (5) [1].

[3] Variance in assessment result.

Permissible variance due to differences in equipment (units) shall be determined in the future.

5.2.5.4. LTE-Advanced Base Station Equipment

(1) Equipment Definition

- An LTE/E-UTRAN base station (eNodeB) that complies with 3GPP standards (Release10 or later).
- Comprises of eNodeB control units and radio units. Does not include maintenance tools, external power sources, rectifiers, remote tilt controller or the like.
- Scope applies to the following implemented configurations

Name	Segregated 10W Device
Output power per sector	10W + 10W
Radio unit and control unit configuration	Segregated

Note:

Segregated: Radio unit and control unit are driven by separate power sources.

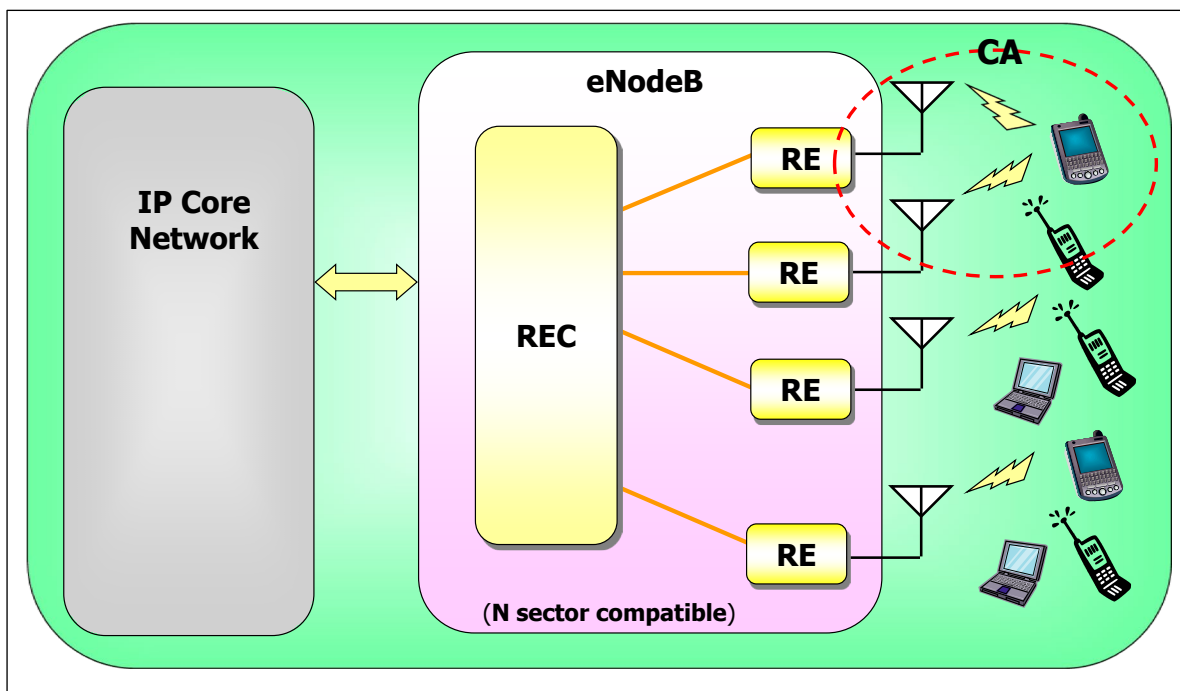

Note:

3GPP: 3rd Generation Partnership Project

LTE: Long Term Evolution CA: Carrier Aggregation

E-UTRAN: Evolved UMTS Terrestrial Radio Access Network

eNodeB: evolved Node B REC: Radio Equipment Control RE: Radio Equipment

【Common Equipment Specifications】

Item	Specifications	Notes
Frequency band	Combination of 2GHz and 800MHz	
Signal bandwidth	10MHz	
Number of carriers	2 Carriers	LTE-Advanced
Number of sectors	24	
Number of antennas	Transmit: 2 Receive: 2 (space diversity)	MIMO
Radio access method	Transmit: OFDMA Receive: SC-FDMA	
Multiplexing method	FDD	
Modulation method	Transmit: QPSK, 16QAM, 64QAM Receive: QPSK, 16QAM	
S1 interface	Gigabit Ethernet x n or 10Gigabit Ethernet x n	n:1 or more
Primary Power supply input	DC -48V	
Redundancy configuration	Not applicable	

MIMO: Multiple Input Multiple Output

OFDMA: Orthogonal Frequency Division Multiple Access

SC-FDMA: Single Carrier-Frequency Division Multiple Access

FDD: Frequency Duplex Division

QPSK: Quadrature Phase Shift Keying

16QAM: 16 Quadrature Amplitude Modulation

64QAM: 64 Quadrature Amplitude Modulation

(2) Figures of Merit

- LTE-Advanced base station equipment figure of merit shall be the maximum throughput per average power consumption.

$$\text{Figure of Merit: } E = \sum T_i / [P_{\text{idle}} \times (1 - \alpha) + P_{\text{max}} \times \alpha]$$

T_i : Maximum throughput per 1CA cell (i) in P_{max} state (measured) (Mbps)

Due to difficulty of measurement under the operating conditions including the commercial terminals,

$\sum T_i$ = Maximum theoretical value of the device, by the signal bandwidth 10Mhz, the number of sectors \times 150Mbps.

P_{idle} : Primary supply-side input power (W) when there is no load, with no traffic.

P_{max} : Primary supply-side input power (W) during maximum throughput, with maximum traffic.

α : Daily average transmission traffic rate

Calculate using $\alpha=0.5$ due to lack of available operating data.

“Power consumption = power consumption of REC + power consumption of REC \times number of cells”.

(3) Normative References

[1] Method for determining normative references

Normative references for the abovementioned three types of LTE-Advanced base station equipment (Segregated 10W Device) shall reflect improvements upon average values for current products (per CIAJ) based on technical trends.

【Normative References】

Segregated 10W Device of 24 sectors type: 0.4542 (Mbps/w)

<Reference> Informative value of 6 sectors type

Segregated 10W Device of 6 sectors type: 0.3600 (Mbps/w)

【Approximate Date for Achieving Normative References】

End of Fiscal Year 2018

[2] Assessment scale references

Set a threshold using the rate of reduction versus the power consumption at normative reference. In assessment scale, the rank including normative reference shall be ★★.

Average power consumption for normative reference for segregated 10W equipment of 24 sectors type: 7,926.02(w)

Assessment Scale	Rate of reduction vs. power consumption at NR	Average power consumption normative reference (W) for segregated 10W equipment (24 sectors type)
★★★★★	$n \geq 15\%$	$P \leq 6,737.11$
★★★★★	$10\% \leq n < 15\%$	$6,737.11 < P \leq 7,133.41$
★★★	$5\% \leq n < 10\%$	$7,133.41 < P \leq 7,529.71$
★★ (include NR)	$0\% \leq n < 5\%$	$7,529.71 < P \leq 7,926.02$
★	Normative reference not achieved	$P > 7,926.02$

(Note) In power consumption, calculate values to the second decimal place.

(4) Measurement Methodology
 [1] Measurement configuration

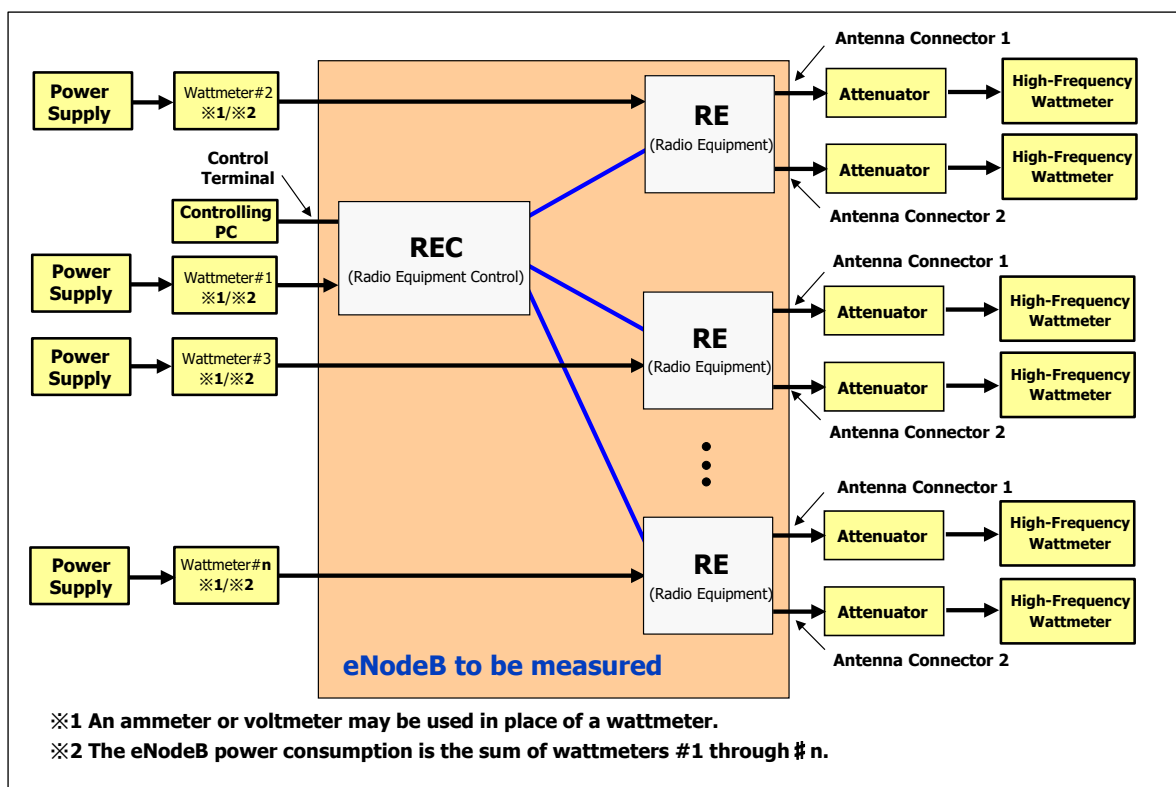

[2] Measurement conditions

【Environment and Electrical Conditions】

Item		Condition	Notes
Environment conditions	Room temperature	+25°C±5°C	
Primary supply-side input power voltage	DC	DC -48V ± 1%	

【Non-Environmental and Electrical Conditions】

- (a) This guideline does not stipulate the number of units of eNodeB equipment to be measured. However, use an average value when measuring multiple units.
- (b) This guideline does not stipulate the number of times measurements shall be taken for each item in relation to an eNodeB equipment. However, use an average value when measuring multiple times.
- (c) The following functions are necessary functions for an eNodeB and the measurement shall be conducted when continuous power is supplied to these functions.
 - Upstream receiving current, line interface, (S1/X2 interface), RRC processor, MAC processor, RLC processor, and PDCP processor.
- (d) Begin measurements after the equipment has been exposed to room

- temperature for one or more hours with the power on.
 (e) Set in the system configuration that put out the maximum throughput in all sectors.

MAC: Medium Access Control, PDCP: Packet Data Convergence Protocol,
 RLC: Radio Link Control, RRC: Radio Resource Control

【Measurement Methodology】

Item		Measurement method
1. Test paturan transmission		
Primary supply-side input power at maximum transmission power	Pmax	Set to 3GPP TS36.141 E-TM1.1 transmission state.
Primary supply-side input power when there is no load	Pidle	Set to 3GPP TS36.141 E-TM1.1 transmission state without the traffic resource blocks. Furthermore, operational conditions with no traffic (but with broadcast information) shall be permissible.
2. Measurement of power consumption		Measure using a wattmeter under the measurement conditions of 1. (Using an ammeter or voltmeter is acceptable.)

(5) Assessment Result and Assessment Scale Ranking

[1] Assessment result

The assessment result shall be the figure of merit actually measured by the vendor according to 5.2.5.4(4) Measurement Methodology.

[2] Assessment scale ranking

The assessment scale ranking (★-★★★★★) shall be based on normative reference and assessment result in 5.2.5.4(5) [1].

[3] Variance in assessment result

Permissible variance due to differences in equipment (units) shall be determined in the future.

5.2.5.5 5G Base Station Equipment

(1) Definition

- A 5G base station (gNodeB) that complies with 3GPP standards (Release16 or later).
- Does not include maintenance tools, external power sources, rectifiers, remote tilt controller or the like.
- Scope applies to the following implemented configuration.

Name	Implementation configuration
Output power per sector	20W×4

Note:

3GPP: 3rd Generation Partnership Project

gNodeB: Next Generation Node B

【Equipment Configuration Diagram (one example)】

- gNodeB comprises a digital processing unit (CU/DU) and radio units (RU).

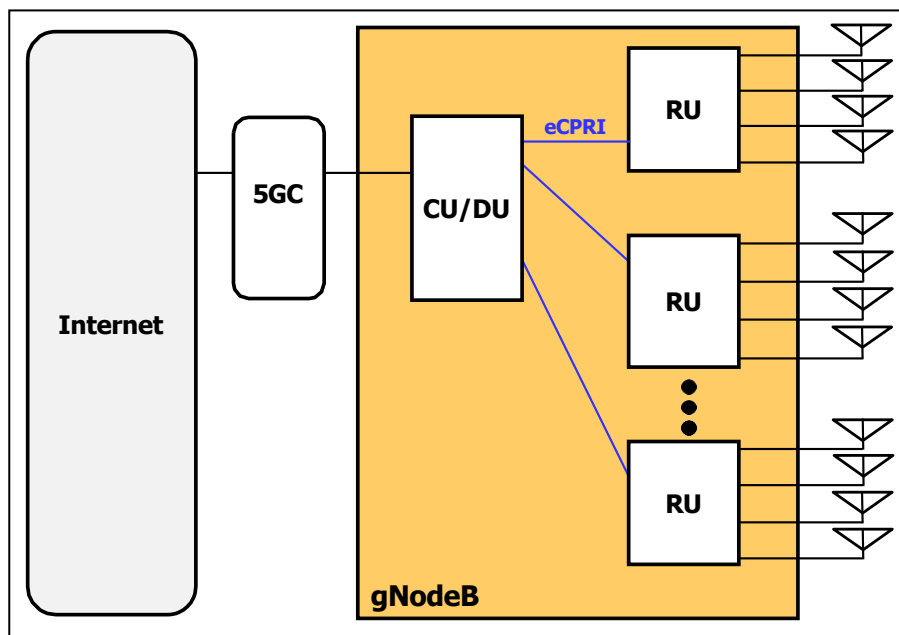

Note:

5GC: 5G Core

CU : Central Unit

DU : Distributed Unit

RU : Radio Unit

eCPRI : evolved Common Public Radio Interface

【Common Equipment Specifications】

Item	Specifications	Notes
Frequency band	3.7GHz band (n77/n78) or 4.5GHz band (n79)	
Signal bandwidth	100MHz	
Number of carriers	1 Carrier	
Number of antennas	Transmit: 4 Receive: 4 (space diversity)	MIMO
Radio access method	Transmit: OFDMA Receive: SC-FDMA/OFDMA	
Multiplexing method	TDD	
Modulation method	Transmit: QPSK, 16QAM, 64QAM, 256QAM Receive: QPSK, 16QAM, 64QAM	
Primary power supply input	DC -48V	
Redundancy configuration	Not applicable	

Note:

MIMO: Multiple Input Multiple Output

OFDMA: Orthogonal Frequency Division Multiple Access

SC-FDMA: Single Carrier-Frequency Division Multiple Access

TDD: Time Division Duplex

QPSK: Quadrature Phase Shift Keying

16QAM: 16 Quadrature Amplitude Modulation

64QAM: 64 Quadrature Amplitude Modulation

256QAM: 256 Quadrature Amplitude Modulation

(2) Figure of Merit

- 5G base station equipment figure of merit shall be the maximum throughput (Mbps) per average power consumption (W).

$$\text{Figure of merit: } E = \sum T_i / [P_{\text{idle}} \times (1 - \alpha) + P_{\text{max}} \times \alpha]$$

T_i : Maximum throughput (Mbps) per cell (i) in P_{max} state

$\sum T_i$: Maximum theoretical value of the equipment (complies with 3GPP

TS 38.306 V16.8.0. The DL assignment index of TDD shall be 0.74.

The throughput per component carrier (CC) shall be 1,730Mbps.)

P_{idle} : Primary supply-side input power (W) when there is no load.

P_{max} : Primary supply-side input power (W) during maximum throughput.

α : Daily average transmission traffic rate (α shall be 0.5)

(3) Nominative references

- [1] Method for determining normative references

Normative references for the abovementioned 5G base station equipment with an implementation configuration of 20W×4 shall reflect improvements upon average values for current products (per CIAJ) based on technical trends.

【Normative references】

This shall be a reference value because there is not enough data on the figure of merit for the present product.

〈Reference value〉

20W×4 units: 3.1803 (Mbps/w)

【Approximate Date for Achieving Normative References】

This is not set because there are no normative references.

[2] Assessment scale references

This is not set because there are no normative references.

(4) Measurement Methodology

[1] Measurement configuration (one example)

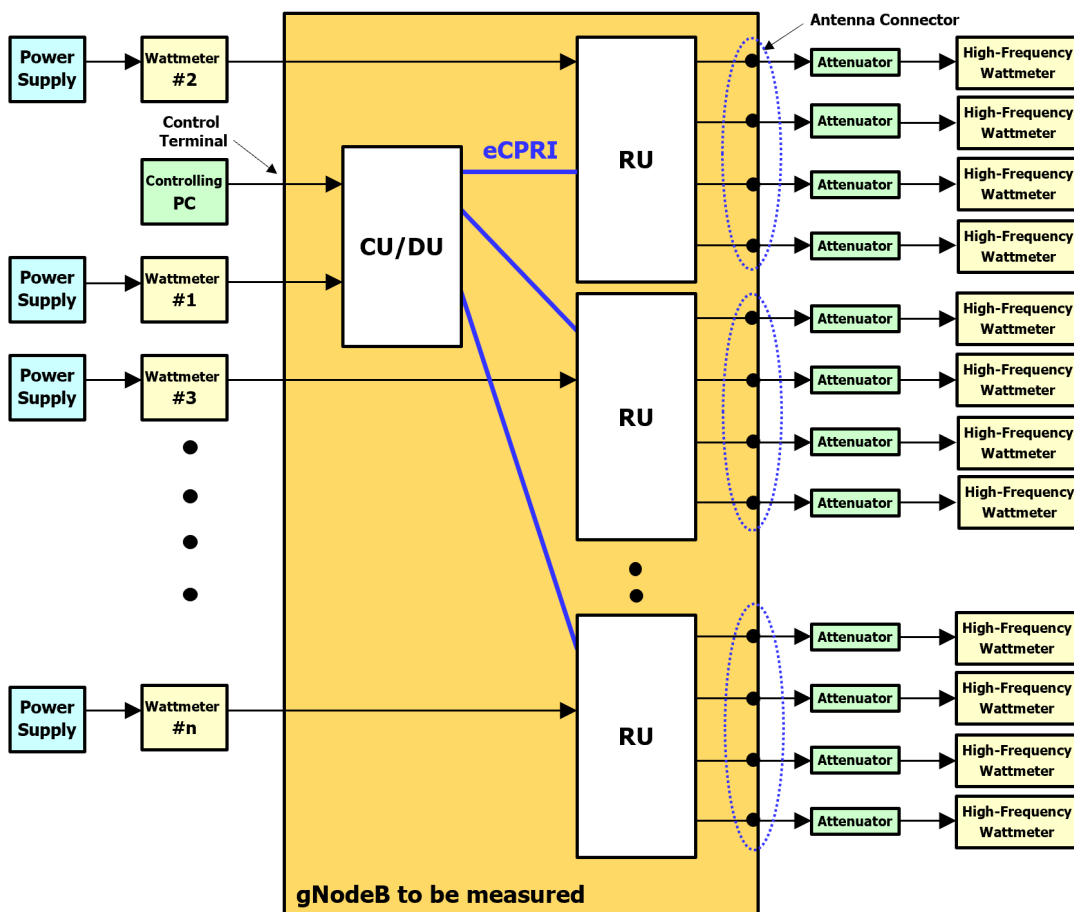

[2] Measurement methodology

【Measurement methodology (one example)】

- (a) The required number of RUs* will be connected via eCPRI to enable as many launches of the equipment and as many transports of signals as there are cells that can be handled by the CU/DU.
*:Refer to a type of device with a maximum rated power at the antenna end of 20W or more being applied.
- (b) Connect wattmeters to the supply power inputs of the CU/DU and all connected RUs as shown by #1 to #n in the measurement configuration diagram.
- (c) The control PC sets the transmission by the CU/DU of the test pattern signals for all cells to either the ON or OFF state.
- (d) Measure the power consumption of the CU/DU and each RU in the ON state and in the OFF state during the transmission of test pattern signals. P_{max} is the total of the measured values using wattmeters #1 to #n in the transmission ON state, and P_{idle} the total of the measured values in the transmission OFF state.
- (e) Measure the power consumption using the wattmeters connected to the equipment while the test pattern transmission for each cell is set as follows.

Measured item		Measurement conditions
Primary supply-side input power at maximum transmission power	P_{max}	A state in which downstream signals (test pattern) are transmitted from all RU antenna systems under the following conditions.
Primary supply-side input power when there is no load	P_{idle}	A state in which the traffic resource blocks are removed from the following test pattern. Furthermore, operational conditions with no traffic (but with broadcast information) shall be permissible.

【Downstream signal (test pattern) transmission conditions】

No.	Item	Operating conditions
1	Number of RU antenna systems	4
2	Transmission power at each antenna end	20W or more
3	Number of transmission layers	1, 2, and 4
4	Test pattern	NR-FR1-TM1.1 (complies with 3GPP TS

		38.141-1)
--	--	-----------

(5) Assessment Result and Variance in Assessment Result

[1] Assessment result

The assessment result shall be the figure of merit actually measured by the vendor according to 5.2.5.4(4) Measurement Methodology.

[2] Variance in assessment result

Permissible variance due to differences in equipment (units) shall be determined in the future.

5.2.6. Power Equipment

5.2.6.1. External Power Source (AC Adapters)

(1) Equipment Definition

In this Guideline, the term refers to an AC-DC converter that takes AC commercial power supply and provides DC power to the equipment.

This assessment applies to external power sources for customer-premises equipment having a name plate output (rated output) P_{no} (P_{no} : Nameplate Output Power) of $1W < P_{no} \leq 49W$.

This assessment applies to AC adapters procured separately. Those which come as an attachment with equipment shall be assessed as part of the equipment itself and shall be excluded from the assessment of this section.

(2) Figure of merit

The figures of merit are established in reference to the figures of merit set forth Energy Conservation Program (Energy Conservation Standards for Battery Charges and External Power Supplies released by the U.S. Department of Energy). Evaluate average conversion efficiency η at nameplate output P_{no} (W) based on conversion efficiency at 25% load η_{25} , conversion efficiency at 50% load η_{50} , conversion efficiency at 75% load η_{75} and conversion efficiency at 100% load η_{100} .

$$\eta = (\eta_{25} + \eta_{50} + \eta_{75} + \eta_{100}) / 4$$

(3) Normative References

[1] Method for determining normative references

- The values designated in the Energy Conservation Program(U.S. Department of Energy) shall be used as normative references .
- Decide individual normative references for each nameplate output.

[Normative References]

- The normative reference for standard voltage (6V and above) and low voltage (less than 6V) shall differ depending on output voltage.
 - <Standard voltage (6V and above)>
 - The normative reference of the average conversion efficiency η shall be $[0.071 \ln(P_{no}) - 0.0014 P_{no} + 0.67]$
 - The conversion efficiency at 10% load shall be 5% less than the value calculated above
 - The standby power consumption shall be 0.075W or less.
 - < Low voltage (less than 6V)>
 - The normative reference of the average conversion efficiency η shall be $[0.00834 \ln(P_{no}) - 0.0014 P_{no} + 0.609]$
 - The conversion efficiency at 10% load shall be 5% less than the value calculated above
 - The standby power consumption shall be 0.03W or less.

[Approximate Date for Achieving Normative References]
End of Fiscal Year 2019

[2] Assessment scale references

Set a threshold using the rate of reduction versus the power consumption at normative reference. In assessment scale, the rank including normative reference shall be ★★.

Standard voltage (6V and above)

Assessment scale	Rate of reduction vs. power consumption at NR	Average conversion efficiency η (%)
★★★★★	$n \geq 30\%$	$\eta \geq 0.05778 \ln(P_{no}) - 0.0012 P_{no} + 0.746$
★★★★	$20\% \leq n < 30\%$	$0.0628 \ln(P_{no}) - 0.00129 P_{no} + 0.719 \leq \eta < 0.05778 \ln(P_{no}) - 0.0012 P_{no} + 0.746$
★★★	$10\% \leq n < 20\%$	$0.0674 \ln(P_{no}) - 0.00136 P_{no} + 0.694 \leq \eta < 0.0628 \ln(P_{no}) - 0.00129 P_{no} + 0.719$
★★ (includes NR)	$0\% \leq n < 10\%$	$0.071 \ln(P_{no}) - 0.0014 P_{no} + 0.67 \leq \eta < 0.0674 \ln(P_{no}) - 0.00136 P_{no} + 0.694$
★	Normative reference not achieved	$\eta < 0.071 \ln(P_{no}) - 0.0014 P_{no} + 0.67$

(Note) P_{no} : Nameplate Output Power (W)

Low voltage (less than 6V)

Assessment scale	Rate of reduction vs. power consumption at NR	Average conversion efficiency η (%)
★★★★★	$n \geq 30\%$	$\eta \geq 0.00694 \ln(P_{no}) - 0.00127 P_{no} + 0.694$
★★★★	$20\% \leq n < 30\%$	$0.0745 \ln(P_{no}) - 0.00130 P_{no} + 0.664 \leq \eta < 0.00694 \ln(P_{no}) - 0.00127 P_{no} + 0.694$

★★★	$10\% \leq n < 20\%$	$0.0793 \ln(P_{no}) - 0.00136 P_{no} + 0.636 \leq \eta < 0.0745 \ln(P_{no}) - 0.00130 P_{no} + 0.664$
★★ (includes NR)	$0\% \leq n < 10\%$	$0.0834 \ln(P_{no}) - 0.0014 P_{no} + 0.609 \leq \eta < 0.0793 \ln(P_{no}) - 0.00136 P_{no} + 0.636$
★	Normative reference not achieved	$0.0834 \ln(P_{no}) - 0.0014 P_{no} + 0.609$

(Note) P_{no} : Nameplate Output Power (W)

(4) Measurement Methodology

[1] Measurement system

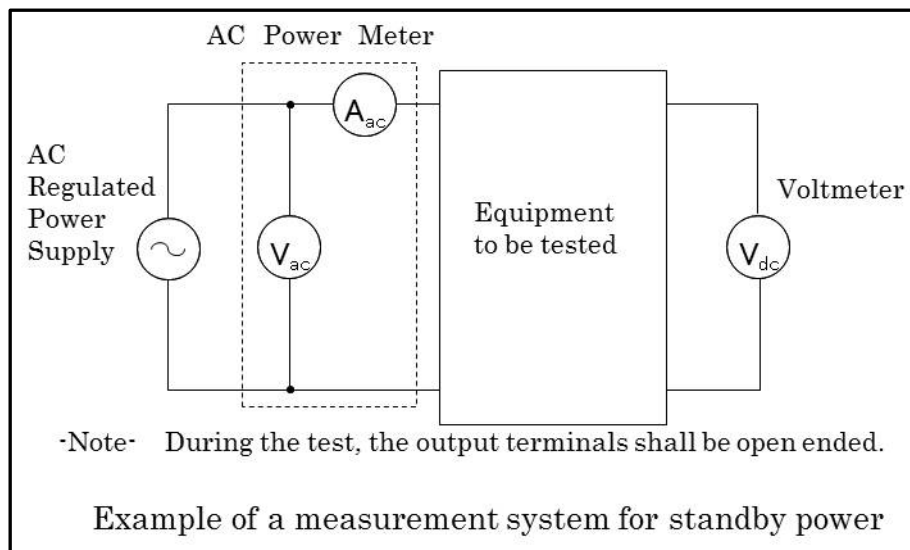
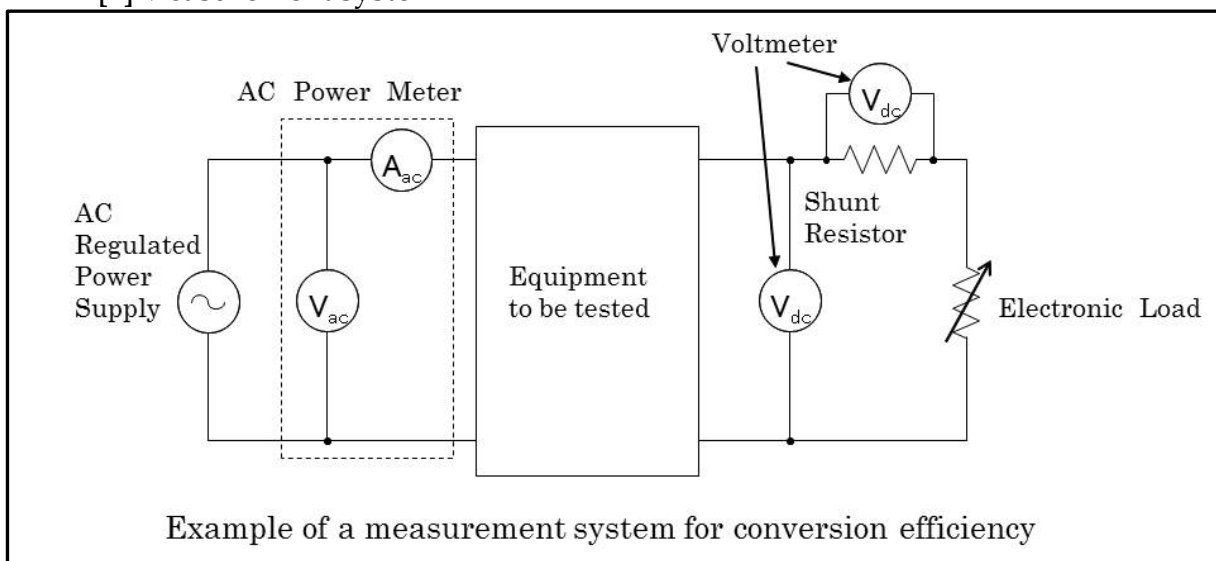

AC regulated power supply

The AC regulated power supply shall have the output power capacity that is ten times greater than the rated output power of the AC adaptor to be tested, and the voltage and frequency accuracy within $\pm 1\%$.

Shunt resistor

The shunt resistance shall match the rated output power of the AC adapter to be tested, and the resistance accuracy within $\pm 1\%$.

Electronic load

The electronic load shall match the rated output of the AC adapter to be tested.

[2] Measurement procedure

Using variable resistance, measure conversion efficiencies η_{100} , η_{75} , η_{50} and η_{25} at nameplate currents of 100%, 75%, 50%, and 25%, respectively, and seek the average value η .

[3] Measurement conditions

- Room temperature: $23^{\circ}\text{C} \pm 5^{\circ}\text{C}$. Do not intentionally cool the AC adapter to be tested. Additionally, the AC adapter to be tested shall be placed on a non-heat transfer surface and measured.
- Error tolerance of measurement equipment: the calibrated voltmeter/ammeter or wattmeter shall be used.
Error tolerance: No more than 2% error for the ammeter/voltmeter.
Precision of no less than 0.01 W for the wattmeter.
- Voltage applied: Measure upon applying voltage of 100 V (± 1 V) at frequencies of 50 Hz (\pm Hz) and 60 Hz (± 0.6 Hz). The peak value of the applied voltage shall be within the range from 1.34 times to 1.49 times greater than the effective value of the applied voltage.
- Preparations prior to measurement: Begin measurements after running 100% nameplate current through the external power source to be tested for no less than 30 minutes.

(5) Assessment Result and Assessment Scale Ranking

[1] Assessment result

The assessment result shall be the figure of merit actually measured by the vendor according to 5.2.6.1(4) Measurement Methodology.

[2] Assessment scale ranking

The assessment scale ranking (★-★★★★★) shall be based on normative reference and assessment result.

[3] Variance in assessment result

Permissible variance due to differences in equipment (units) shall be determined in the future.

Until then, submit the average measurement value of the figure of merit determined by the vendor as the assessment result.

5.2.6.2. Rectifiers

(1) Equipment Definition

A rectifier refers to AC-DC converters that receive primary energy from a commercial power supply, and supplies DC power to equipments such as a network equipment and server equipment, while floating-charges a storage battery the insulated secondary energy, which is a backup power source.

Applies to modules having an insulated power conversion function of power supply for telecommunications or cellular phone base stations and ICT equipment.

However, this standard power supply does not apply to wireless base stations other than cellular phone base stations or to thyristor rectifiers. Furthermore, the output voltage is a nominal DC 48V and 380V.

(2) Figure of Merit

The figure of merit is based on ATIS specified TEER※1, and shall be calculated using the following formula.

$$TEER = \frac{\sum_{i=3}^8 \eta(i \times 10\%)}{6} \times 1,000$$

$$\eta = \frac{P_{out}}{P_{in}}$$

Single-phase AC input: $P_{in}[\text{input power}] = V_{in}[\text{input voltage}] \times I_{in}[\text{input current}] \times PF[\text{power factor}]$

Three-phase AC input: $P_{in} = V_{in} \times I_{in} \times PF \times \sqrt{3}$

DC output: $P_{out}[\text{output power}] = V_{out}[\text{output voltage}] \times I_{out}[\text{output current}]$

※1: ATIS-0600015.04.2010: Energy Efficiency for Telecommunication Equipment: Methodology for Measurement and Reporting DC Plant - Rectifier Requirements

(3) Normative References

[1] Method for determining normative references

The normative references were determined by calculating the equipment TEER and analyzing product trends.

【Normative References】

Single-phase AC100V input, 48V output rectifier: TEER=872

Single-phase AC200V input, 48V output rectifier: TEER=878

Three-phase AC200V/400V input, 48V output rectifier (output power capacity of less than 5kW): TEER=891

Three-phase AC200V/400V input, 48V output rectifier (output power

capacity of 5kW or more): TEER=908

Three-phase AC200V/400V input, 380V output rectifier: TEER=944

【Approximate Date for Achieving Normative References】

End of Fiscal Year 2017 (48V output rectifier)

End of Fiscal Year 2017 (380V output rectifier)

[2] Assessment scale references

Set a threshold using the rate of reduction versus the power consumption at normative reference. In assessment scale, the rank including normative reference shall be ★★.

Use the applicable assessment scale standard for equipment that supports multiple inputs such as single-phase AC100V/200V common systems.

Single-phase AC100V input, 48V output rectifier

Assessment Scale	Rate of reduction vs. power consumption at NR	Figure of Merit (TEER)
★★★★★	$n \geq 45\%$	$TEER \geq 926$
★★★★★	$30\% \leq n < 45\%$	$907 \leq TEER < 926$
★★★	$15\% \leq n < 30\%$	$889 \leq TEER < 907$
★★ (includes NR)	$0\% \leq n < 15\%$	$872 \leq TEER < 889$
★	Normative reference not achieved	$TEER < 872$

Single-phase AC200V input, 48V output rectifier

Assessment Scale	Rate of reduction vs. power consumption at NR	Figure of Merit (TEER)
★★★★★	$n \geq 45\%$	$TEER \geq 929$
★★★★★	$30\% \leq n < 45\%$	$911 \leq TEER < 929$
★★★	$15\% \leq n < 30\%$	$894 \leq TEER < 911$
★★ (includes NR)	$0\% \leq n < 15\%$	$878 \leq TEER < 894$
★	Normative reference not achieved	$TEER < 878$

Three-phase AC200V/400V input, 48V output rectifier (output power capacity of less than 5kW)

Assessment Scale	Rate of reduction vs. power consumption at NR	Figure of Merit (TEER)
★★★★★	$n \geq 30\%$	$TEER \geq 921$
★★★★★	$20\% \leq n < 30\%$	$911 \leq TEER < 921$
★★★	$10\% \leq n < 20\%$	$901 \leq TEER < 911$
★★ (includes NR)	$0\% \leq n < 10\%$	$891 \leq TEER < 901$
★	Normative reference not achieved	$TEER < 891$

Three-phase AC200V/400V input, 48V output rectifier (output power capacity of 5kW or more)

Assessment Scale	Rate of reduction vs. power consumption at NR	Figure of Merit (TEER)
★★★★★	$n \geq 30\%$	$TEER \geq 934$
★★★★	$20\% \leq n < 30\%$	$925 \leq TEER < 934$
★★★	$10\% \leq n < 20\%$	$916 \leq TEER < 925$
★★ (includes NR)	$0\% \leq n < 10\%$	$908 \leq TEER < 916$
★	Normative reference not achieved	$TEER < 908$

Three-phase AC200V/400V input, 380V output rectifier

Assessment Scale	Rate of reduction vs. power consumption at NR	Figure of Merit (TEER)
★★★★★	$n \geq 30\%$	$TEER \geq 960$
★★★★	$20\% \leq n < 30\%$	$955 \leq TEER < 960$
★★★	$10\% \leq n < 20\%$	$949 \leq TEER < 955$
★★ (includes NR)	$0\% \leq n < 10\%$	$944 \leq TEER < 949$
★	Normative reference not achieved	$TEER < 944$

(4) Measurement Methodology

In light of the stipulations of ATIS, the following measurement conditions shall be used.

- Room temperature: $25^{\circ}\text{C} \pm 3^{\circ}\text{C}$
- Humidity: 30%-75%
- Error tolerance of measurement equipment: Use voltmeters, ammeters or wattmeters that have been calibrated.

Measurement precision:

Ammeters and voltmeters: within $\pm 1\%$

Wattmeters: within $\pm 1\%$.

- Voltage applied: Measure after applying single-phase 100V ($\pm 1\%$) or single-phase 200V ($\pm 1\%$), three-phase 200V ($\pm 1\%$) or three-phase 400V ($\pm 1\%$) at a frequency of 50Hz ($\pm 1\%$) or 60Hz ($\pm 1\%$).
- Preparations before measurement: Apply current equivalent to 100% of nameplate current to the module to be tested for at least 30 minutes before beginning measurements.

(5) Assessment Result and Assessment Scale Ranking

[1] Assessment result

The assessment result shall be the figure of merit actually measured by the vendor according to 5.2.6.2 (4) Measurement Methodology.

[2] Assessment scale ranking

The assessment scale ranking (★-★★★★★) shall be based on normative reference and assessment result.

[3] Variance in assessment result

Permissible variance due to differences in equipment (units) shall be determined in the future.

Until then, submit the average measurement value of the figure of merit determined by the vendor as the assessment result.

5.2.6.3 UPS

(1) Definition

An Uninterruptible Power System (UPS) is a combination of the semiconductor power converter, switch and energy storage device (such as fuel cells). It is a power supply unit which ensures uninterrupted load power during power failures.

The scope of the assessment shall cover the following continuous inverter power type UPS:

- 1) Rated output voltage for three-phase 200V with trans, where rated load is 200 kVA or above.
- 2) Rated output voltage for three-phase 415V with trans, where rated load is 500 kVA or above.
- 3) Rated output voltage for three-phase 200V transless, where rated load is 200 kVA or above and less than 500 kVA.
- 4) Rated output voltage for three-phase 415V transless, where rated load is 200 kVA or above.

(2) Figure of Merit

The figure of merit shall be the average efficiency η of load rates at four points (25%, 50%, 75%, 100%). The average efficiency η shall be calculated as follows.

$$\eta = (\eta_{25} + \eta_{50} + \eta_{75} + \eta_{100})/4$$

(3) Normative reference

[1] Method for determining normative references

The normative reference shall be an enhanced value using the IEC average guideline value as reference and taking product trends into account.

【Normative reference】

Three-phase 200V UPS (200 kVA or above and less than 500 kVA): $\eta = 89.2$ (%)

Three-phase 200V UPS (500 kVA or above): $\eta = 89.9$ (%)

Three-phase 415V UPS (500 kVA or above): $\eta = 90.9$ (%)

Three-phase 200V transless UPS (200 kVA or above and less than 500 kVA): $\eta = 92.7$ (%)

Three-phase 415V transless UPS (200 kVA or above and less than 500 kVA): $\eta = 95.5$ (%)

Three-phase 415V transless UPS (500 kVA or above): $\eta = 96.2$ (%)

【Approximate Date for Achieving Normative References】

End of Fiscal Year 2018.

[2] Assessment scale references

Set a threshold using the rate of reduction versus the power consumption at normative reference. In assessment scale, the rank including normative reference shall be ★★.

If the average efficiency and average conversion efficiency for the UPS rated output voltage are not indicated in the table, they shall be calculated by using the line interpolation of the voltage value based on the concept articulated in IEC62040-3:2011 Annex I (Informative).

a) Three-phase 200V with trans, 200 kVA or above and less than 500 kVA.

Assessment scale	Rate of reduction vs. power consumption at NR	Average conversion efficiency η
★★★★★	$n \geq 45\%$	$\eta \geq 93.7$
★★★★	$30\% \leq n < 45\%$	$92.2 \leq \eta < 93.7$
★★★	$15\% \leq n < 30\%$	$90.6 \leq \eta < 92.2$
★★ (includes NR)	$0\% \leq n < 15\%$	$89.2 \leq \eta < 90.6$
★	Normative reference not achieved	$\eta < 89.2$

b) Three-phase 200V with trans, 500 kVA or above.

Assessment scale	Rate of reduction vs. power consumption at NR	Average conversion efficiency η
★★★★★	$n \geq 45\%$	$\eta \geq 94.2$
★★★★	$30\% \leq n < 45\%$	$92.7 \leq \eta < 94.2$
★★★	$15\% \leq n < 30\%$	$91.3 \leq \eta < 92.7$
★★ (includes NR)	$0\% \leq n < 15\%$	$89.9 \leq \eta < 91.3$
★	Normative reference not achieved	$\eta < 89.9$

c) Three-phase 415V with trans, 500 kVA or above.

Assessment scale	Rate of reduction vs. power consumption at NR	Average conversion efficiency η
★★★★★	$n \geq 45\%$	$\eta \geq 94.8$
★★★★	$30\% \leq n < 45\%$	$93.5 \leq \eta < 94.8$
★★★	$15\% \leq n < 30\%$	$92.2 \leq \eta < 93.5$
★★ (includes NR)	$0\% \leq n < 15\%$	$90.9 \leq \eta < 92.2$
★	Normative reference not achieved	$\eta < 90.9$

d) Three-phase 200V transless, 200 kVA or above and less than 500 kVA.

Assessment scale	Rate of reduction vs. power consumption at NR	Average conversion efficiency η
★★★★★	$n \geq 30\%$	$\eta \geq 94.8$

★★★★★	$20\% \leq n < 30\%$	$94.1 \leq \eta < 94.8$
★★★★	$10\% \leq n < 20\%$	$93.4 \leq \eta < 94.1$
★★ (includes NR)	$0\% \leq n < 10\%$	$92.7 \leq \eta < 93.4$
★	Normative reference not achieved	$\eta < 92.7$

e) Three-phase 415V transless, 200 kVA or above and less than 500 kVA.

Assessment scale	Rate of reduction vs. power consumption at NR	Average conversion efficiency η
★★★★★★	$n \geq 45\%$	$\eta \geq 97.5$
★★★★★	$30\% \leq n < 45\%$	$96.8 \leq \eta < 97.5$
★★★★	$15\% \leq n < 30\%$	$96.1 \leq \eta < 96.8$
★★ (includes NR)	$0\% \leq n < 15\%$	$95.5 \leq \eta < 96.1$
★	Normative reference not achieved	$\eta < 95.5$

f) Three-phase 415V transless, 500 kVA or above.

Assessment scale	Rate of reduction vs. power consumption at NR	Average conversion efficiency η
★★★★★★	$n \geq 45\%$	$\eta \geq 97.9$
★★★★★	$30\% \leq n < 45\%$	$97.3 \leq \eta < 97.9$
★★★★	$15\% \leq n < 30\%$	$96.8 \leq \eta < 97.3$
★★ (includes NR)	$0\% \leq n < 15\%$	$96.2 \leq \eta < 96.8$
★	Normative reference not achieved	$\eta < 96.2$

(4) Measurement Methodology

The measurement conditions and methodology for UPS efficiency (η) shall be compliant with IEC 62040-3:2011.

[1] Measurement conditions

a) Environmental conditions

Environmental conditions must be maintained within the following parameters.

Ambient temperature: 20°C ~ 30°C

Humidity: 20% ~ 80%

Altitude: 1,000 m or below

b) Operational and electrical conditions

Measurement of efficiency for UPS shall be conducted with the standard test load set as load power factor 1 and active power can be set to 25%, 50%, 75% and 100% versus the rated output. The requirements for each measurement shall be as follows.

1) UPS shall be run at normal operational state.

2) Energy storage systems shall be disconnected.

3) The UPS and the load shall be run for a sufficient time in order to

achieve a stable state. A testing duration of 125% of the time spent in testing temperature rise shall be deemed sufficient. An alternative condition deemed as stable state shall be where temperature difference of 2°C or less is recorded at 10-minute or longer intervals for at least 3 consecutive readings.

- 4) Each load condition shall be within 95% ~ 105% of target load and the load power rate shall be 0.99 or above.
- 5) All ancillary systems which run in normal operational state shall be running during measurement.
- 6) Input conditions of UPS alternate current shall be one of the following.
 - Rated voltage of 97% ~ 103% and rated frequency between 99% ~ 101%.
 - Within the voltage distortion listed in the table below and nominal frequency of ±1 Hz.

Odd order harmonic that are not multiples of 3		Odd order harmonic that are multiples of 3		Even order harmonic	
Harmonic order (h)	Harmonic voltage (%)	Harmonic order (h)	Harmonic voltage (%)	Harmonic order (h)	Harmonic voltage (%)
5	6	3	5	2	2
7	5	9	1.5	4	1
11	3.5	15	0.4	6	0.5
13	3	21	0.3	8	0.5
17<h≤49	2.27 × (17/h) - 0.27	21<h≤45	0.2	10<h≤50	0.25 × (10/h) + 0.25

c) Measuring equipment

The combination of measuring equipment and transducer used in measuring UPS efficiency must satisfy the following conditions.

- Even in cases where harmonic component is included in voltage and/or current wave form, accurate effective value measurement must be taken of effective power input and output, within 0.5% deviation with rated load at 95% confidence level.
- Input and output must be measured simultaneously.

The margin for efficiency shall be calculated as follows, with the limits for conventional efficiency at - 0.2% and actual efficiency at - 0.6%.

$$-20\left(1 - \frac{\eta}{100}\right) \quad (\%)$$

[2] Measurement methodology

a) Standard method

Conduct the UPS efficiency measurement according to the conditions designated in [1] a) and b), using the measuring equipment indicated in [1] c) and following the procedures below.

- 1) When measuring normative testing load at 100%, it will be necessary to allow sufficient time to reach stable state mentioned above after

connecting the UPS output.

- 2) The effective input and output power shall be measured 3 consecutive times within 15-minute intervals each. UPS efficiency shall be calculated from each reading.
- 3) Get the arithmetic average from the UPS efficiency figures calculated in 2). The result shall be the measured efficiency figure.
- 4) Load conditions of 75%, 50% and 25% shall be done separately by repeating procedures 1), 2) and 3) respectively.

b) Alternative method

If it is difficult to gain access to compliant measuring equipment and/or transducer indicated in [1] c), the following standard method may be used as an alternative.

Step 3) in procedure [2] a) shall be replaced with the following.

The measuring equipment and/or transducer attached to the input and output shall be exchanged and step a) 2) above shall be repeated. A total of 6 UPS efficiency measurement results shall be gained for use in calculating the arithmetic average, which shall be the efficiency measurement figure.

(5) Assessment Result and Assessment Scale Ranking

[1] Assessment result

The assessment result shall be the figure of merit actually measured by the vendor according to 5.2.6.3 (4) Measurement Methodology.

[2] Assessment scale ranking

The assessment scale ranking (★-★★★★★) shall be based on normative reference and assessment result.

5.2.7 Server Equipment

5.2.7.1. Servers

The assessment standard for servers shall adopt the top runner method for computers (2019 Ministerial Notification No. 69 from the Ministry of Economy, Trade and Industry), which are specified equipment in the Energy Conservation Law.

(1) Definition

In this Guideline, a server is a computer device comprising of a central processing unit (CPU), a main memory, a storage, an input/output control and a power source. It is designed to exist as part of a network to provide information and services to other computer devices 24/7. It must be able to use an operating system (OS) so that it can be installed with and run user applications. Examples of servers include but are not limited to the following:

- > file servers

- > mail servers
 - > database servers
 - > authentication servers
 - > web servers
 - > media servers
 - > game servers
- * Devices sold as a single unit which are actually a combination of hardware and software (such as appliances) shall be included under servers in this section if all that is needed to change the device to a particular use is the installation of (a) user application(s).

(2) Figure of merit

There was previously no method for evaluating the energy efficiency of components other than the CPU, but we now have an internationally recognized testing method which has even been adopted by the ENERGY STAR program: SERT Ver. 2.0^{*1}. Energy efficiency for the FY 2021 standards is measured using SERT Ver. 2.0.

^{*1}: A server-performance analysis tool created by the Standard Performance Evaluation Corporation (SPEC), a nonprofit organization. SERT Ver. 2.0 establishes methods for measuring the energy efficiency of a computer under a variety of load conditions that simulate actual usage and defining that efficiency in terms of a SERT score.

The energy efficiency of the server computer (its SERT score) is equivalent to the weighted geometric mean of the workloads calculated in workload energy efficiency, with the CPU weight being 65%, the memory weight being 30%, and the storage weight being 5%.

$$E = \text{SERT score} = \exp(0.65 \times \ln(\text{Eff}_{\text{CPU}}) + 0.3 \times \ln(\text{Eff}_{\text{Memory}}) + 0.05 \times \ln(\text{Eff}_{\text{storage}}))$$

Eff_{CPU} : Energy efficiency ratio of CPU workload

$\text{Eff}_{\text{Memory}}$: Energy efficiency ratio of Memory workload

$\text{Eff}_{\text{storage}}$: Energy efficiency ratio of Storage workload

(3) Normative References

[1] Method for determining normative references

Adopt the assessment standard based on the top runner method for computers (Type: server type computers), which are specified equipment in the Energy Conservation Law.

【Normative References】

Specific normative references are as follows:

CPU Type	Number of CPU Sockets	Category name	Energy conservation efficiency (SERT score)
x86	1	1	8.9
	2	2	11.9
	4	3	8.9
SPARC	1	4	6.3
	2	5	4.2
	4	6	3.5
Power	1	7	4.6
	2	8	4.9
	4	9	4.2

Note:

x86 is the name of the instruction set architecture used in the Intel 8086.

SPARC is a RISC-based microprocessor originally developed by Sun Microsystems.

Power refers to a series of RISC microprocessors developed by IBM.

【Approximate Date for Achieving Normative References】

End of Fiscal Year 2021

[2] Assessment scale references

Set a threshold using the rate of improvement versus the energy efficiency at normative reference. In assessment scale, the rank including normative reference shall be ★★.

Assessment Scale	Rate of improvement vs. energy efficiency at NR	Energy efficiency ratio per category En
		All categories (1-9)
★★★★★	$n \geq 30\%$	$0.3 \leq (En-E)/E$
★★★★	$20\% \leq n < 30\%$	$0.2 \leq (En-E)/E < 0.3$
★★★	$10\% \leq n < 20\%$	$0.1 \leq (En-E)/E < 0.2$
★★ (includes NR)	$0\% \leq n < 10\%$	$0 \leq (En-E)/E < 0.1$
★	Normative reference not achieved	$(En-E)/E < 0$

(4) Measurement Methodology

[1] Measurement methodology

Under SERT Ver. 2.0, each component of a server computer (CPU, memory, and storage) is tested using several worklets within a prescribed testing environment.

[2] Measurement conditions

Measurement environment shall be as defined in SERT Ver. 2.0:

Ambient Temperature: between 20°C and the upper thermal limit listed
in the computer specifications

Supply voltage: ±5% of the rated input voltage

Frequency: ±1% of the rated input voltage frequency

(5) Assessment Result and Assessment Scale Ranking

[1] Assessment result

The assessment result shall be the figure of merit actually measured by the vendor according to 5.2.7.1(4) Measurement Methodology.

[2] Assessment scale ranking

The assessment scale ranking (★-★★★★★) shall be based on normative reference and assessment result.

[3] Variance in assessment result

Based on SERT Ver.2.0 measurement methodology, this Guideline does not specify permissible variance.

5.2.8. Storage Equipment

5.2.8.1. Storage Equipment

(1) Equipment Definition

Storage equipment under this guideline shall be storage equipment having multiple disk drives, comprising of a magnetic disk control unit and a magnetic disk unit, and is used with servers as an external storage.

However, this guideline does not apply to storage equipment having a maximum data transmission speed of more than 270 GB per second.

(2) Figure of Merit

Adopt the top runner standard (2021 Ministerial Notification No. 96 from the Ministry of Economy, Trade and Industry) for magnetic disk unit (two or more disk drives can be mounted per magnetic disk unit: subsystems), which are specified equipment in the Energy Conservation Law. The specific figure of merit is as follows.

Figure of Merit: $E = \text{Power consumption (W)} / \text{Storage capacity}^{\ast}(\text{GB})$

[∗]: Maximum amount that can be physically stored. For dedicated mirroring systems, redundant sub systems and disk arrays, include the storage capacity in the mirrored portion, the duplicated portion of the redundant sub system and the redundant portion of the disk array.

(3) Normative References

[1] Method for determining normative references

Adopt the top runner standard for magnetic disk unit (Type: subsystems), which are identified as specified equipment in the Energy Conservation Law. The specific figure of merit is as follows.

【Normative References】

Energy efficiency ratio (E), which is the normative reference, differs per category. With regard to Categories IV and VI below, it is further expressed in the equation with the number of revolutions (N) indicated as a variable.

Specific normative references are as follows.

Category	Number of disk drives that can be mounted	External dimensions of disk drive	Normative references
IV	Between 2 and 11		$E = \exp(1.56 \times \ln(N) - 17.7)$
V	12 or more	Configuration including the 3.5-inch disk drive (width more than 75 mm)	0.0017
VI		Consisting of only the 2.5-inch disk drive (width 75 mm or less)	$E = \exp(0.952 \times \ln(N) - 14.2)$

Examples of normative references by rpm

• For those devices with the number of mountable disk drives between 2 and 11

7,200 rpm: 0.022
 10,000 rpm: 0.036
 15,000 rpm: 0.068

• For those devices with the number of mountable disk drives 12 or more and consisting of only the 2.5-inch disk drive

7,200 rpm: 0.0032
 10,000 rpm: 0.00437
 15,000 rpm: 0.00643

【Approximate Date for Achieving Normative References】

End of Fiscal Year 2023

[2] Assessment scale references

Set a threshold using the rate of reduction versus the power consumption at normative reference. In assessment scale, the rank including normative reference shall be ★★.

Categories IV and V

Assessment scale	Rate of reduction vs. power consumption at NR	Energy consumption efficiency E_n	Notes
★★★★★	$n \geq 60\%$	$E_n \leq E \times 0.4$	Normative references E (W/GB) are based on the table under (3) Normative References.
★★★★	$40\% \leq n < 60\%$	$E \times 0.4 < E_n \leq E \times 0.6$	
★★★	$20\% \leq n < 40\%$	$E \times 0.6 < E_n \leq E \times 0.8$	
★★ (includes NR)	$0\% \leq n < 20\%$	$E \times 0.8 < E_n \leq E$	
★	Normative reference not achieved	$E < E_n$	

Category VI

Assessment scale	Rate of reduction vs. power consumption at NR	Energy consumption efficiency E_n	Notes
★★★★★	$n \geq 30\%$	$E_n \leq E \times 0.7$	Normative references E (W/GB) are based on the table under (3) Normative References.
★★★★	$20\% \leq n < 30\%$	$E \times 0.7 < E_n \leq E \times 0.8$	
★★★	$10\% \leq n < 20\%$	$E \times 0.8 < E_n \leq E \times 0.9$	
★★ (includes NR)	$0\% \leq n < 10\%$	$E \times 0.9 < E_n \leq E$	
★	Normative reference not achieved	$E < E_n$	

(4) Measurement Methodology

Measurement conditions are as follows, taking into account the substance of **the 2021 Ministerial Notification No. 96 from the Ministry of Economy, Trade and Industry**, which sets forth judgment standards, among other things, for manufacturers of computers per the stipulations of the Energy Conservation Law.

The energy consumption efficiency of storage equipment is the power consumption measured using the following methodology and expressed in watts divided by storage capacity **(the maximum amount that can be physically stored. It is the total storage capacity of the disk drives used for data storage and mounted on a magnetic disk unit. It includes the redundant portion of the disk array and the mirrored portion of the mirroring systems, but does not include the logical capacity created by capacity optimization method)** expressed in Gigabytes. However, in cases where actual measurement is difficult, the value may be calculated using a formula.

- [1] Peripheral temperature shall be **18°C-28°C**.
- [2] Power source voltage shall be within **±1%** of rated input voltage. However, for equipment with power consumption of more than 1500W, power source voltage shall be within **±5%** of rated input voltage.

- [3] Power source frequency shall be rated frequency.
- [4] For those in Categories V and VI, take measurements in the maximum configuration, with the necessary power source, buffer cache memory and control device. However, in cases where taking measurements with the maximum configuration is difficult, the manufacturers shall calculate the values using a formula, provided that they indicate the calculation process (In a configuration consisting of a housing that contains the control device (hereafter referred to as “base enclosure”) and a housing that contains no control device (hereafter referred to as “expansion enclosure”), the power consumption of the expansion enclosure can be calculated by subtracting the power consumption of the base enclosure from the power consumption of the configuration consisting of the two housings. The power consumption of the maximum configuration can be calculated by adding the product of the power consumption of an expansion enclosure and the number of expansion enclosure to the power consumption of the base enclosure). For equipment whose configuration can come under Categories V and VI, the measurements shall be taken for the maximum configuration of each category.
- [5] Calculate the average power consumption by measuring the power consumption over 7,200 seconds at intervals of 5 seconds or less with the equipment power on, with the disk spinning and in a state such that it is capable of immediately writing or reading data (hereafter referred to as “ready idle mode”). However, for equipment in Category IV, in cases where ready idle mode cannot be maintained over the measurement period of 7,200 seconds, the manufacturers may shorten the measurement period provided they indicate the measurement process.

(5) Assessment Result and Assessment Scale Ranking

- [1] Assessment result
The assessment result shall be the figure of merit actually measured by the vendor according to 5.2.8.1(4) Measurement Methodology.
- [2] Assessment scale ranking
The assessment scale ranking (★-★★★★★) shall be based on normative reference and assessment result.
- [3] Variance in assessment result
With the announcement of 2021 Ministerial Notification No. 96 from the Ministry of Economy, Trade and Industry, this Guideline does not specify permissible variance.

<Reference> Industrial Air Conditioners

Since industrial air conditioners for machines and equipment are out of scope of JIS, there is no standard for assessing energy efficiency of “industrial air conditioners for computer rooms.” However, there is a “standard for manufacturers in assessing improvements in performance of air conditioners (Ministry of Economy, Trade and Industry, notification 213 *unofficial translation*)” covering air conditioners for people, which is outlined below as reference.

(1) Figure of merit

Annual Performance Factor

(2) Normative reference

The standard energy consumption efficiency (E) shall be calculated to the first decimal place using the equation in the right-hand column of the table below.

Category				Standard energy consumption efficiency or calculation formula thereof
Type and function	Indoor unit type	Cooling capacity	Category name	
Combined system that does not fit into the two categories below	4-directional cassette type	$n < 3.6 \text{ kW}$	aa	$E = 6.0$
		$3.6 \text{ kW} \leq n < 10.0 \text{ kW}$	ab	$E = 6.0 - 0.083 \times (A - 3.6)$
		$10.0 \text{ kW} \leq n < 20.0 \text{ kW}$	ac	$E = 6.0 - 0.12 \times (A - 10)$
		$20.0 \text{ kW} \leq n \leq 28.0 \text{ kW}$	ad	$E = 5.1 - 0.060 \times (A - 20)$
	Other than 4-directional cassette type	$n < 3.6 \text{ kW}$	ae	$E = 5.1$
		$3.6 \text{ kW} \leq n < 10.0 \text{ kW}$	af	$E = 5.1 - 0.083 \times (A - 3.6)$
		$10.0 \text{ kW} \leq n < 20.0 \text{ kW}$	ag	$E = 5.1 - 0.10 \times (A - 10)$
		$20.0 \text{ kW} \leq n \leq 28.0 \text{ kW}$	ah	$E = 4.3 - 0.050 \times (A - 20)$
Multi-split type, controlling operation of indoor units individually		$n < 10.0 \text{ kW}$	ai	$E = 5.7$
		$10.0 \text{ kW} \leq n < 20.0 \text{ kW}$	aj	$E = 5.7 - 0.11 \times (A - 10)$
		$20.0 \text{ kW} \leq n < 40.0 \text{ kW}$	ak	$E = 5.7 - 0.65 \times (A - 20)$
		$40.0 \text{ kW} \leq n \leq 50.4 \text{ kW}$	al	$E = 4.8 - 0.040 \times (A - 40)$
Ducted type whose indoor unit is set on floor or any like type	Non-ducted type	$n < 20.0 \text{ kW}$	am	$E = 4.9$
		$20.0 \text{ kW} \leq n \leq 28.0 \text{ kW}$	an	$E = 4.9$
	Duct type	$n < 20.0 \text{ kW}$	ao	$E = 4.7$
		$20.0 \text{ kW} \leq n \leq 28.0 \text{ kW}$	ap	$E = 4.7$

Note 1: “Ducted type” indicates system connected to ducts at the air outlet.

Note 2: “Multi-split type” indicates a type that has two or more indoor units connected to an outdoor unit.

Note 3: E and A the following values, respectively:

E: standard energy consumption efficiency (unit: annual performance factor)

A: Cooling capacity (unit: kW)

(3) Approximate Date for Achieving Normative References

For each fiscal year from 2015, the normative reference for air conditioners manufactured for industrial use in Japan shall be calculated per cooling capacity in the table above, weighted for the numbers shipped, deriving a harmonic mean and adjusted so that it does not fall below the standard energy consumption efficiency of that category.

5.3 Implementation

5.3.1 Addition of new equipment and review of the existing Guideline

Telecommunications services providers and vendors shall propose the addition of new equipment to be covered in the scope of the Guideline or a review of existing standards based on product trends, such as the emergence of new functions. Upon receipt of a proposal, the Council shall decide on the addition of the indicated equipment, the measurement methodology, normative reference, and the timing of implementation for the new criteria. In addition, the Council shall review the Guideline as deemed appropriate.

6. Assessment Standard for Data Centers

6.1 Basic Approach to the Assessment Standard

A data center is a complex facility combining ICT equipment such as servers, storage equipment, and network equipment with other hardware including air conditioning systems and power converters. Additionally, the various modes of use and contractual agreements that exist contribute to a multifaceted situation. Furthermore, in terms of services, data centers perform a variety of work and individual data centers differ greatly in how and for what processes software is used.

For this reason, establishing a figure of merit on energy-saving as a normative reference for data centers is no easy task. Studies on this issue are currently underway inside and outside of Japan. Therefore, this guideline uses PUE as one figure of merit (details to follow) currently accepted on a wide scale, which serves as a useful reference for data centers to perform CO₂ emission reduction activities and for telecommunications services providers to procure data center services. Even in the case of PUE, which has been adopted on a relatively broad scale, there is insufficient data from actual measurements and little data has been publicly disclosed.

Therefore, to promote CO₂ emission reduction by telecommunications service providers' through energy conservation activities, it is hoped that data center operators measure energy conservation related data (e.g. PUE with clear measurement conditions) and make further efforts in public disclosure.

6.2 Definition

A data center is a space or facility (including air conditioning, power converters, etc.) used exclusively to store the ICT equipment (network equipment, servers, storage equipment, etc.) it operates.

A data center may be a stand-alone building but also could occupy a portion of space in a shared facility (office, etc.) within a building used for other purposes.

However, this guideline covers data centers primarily providing services to external clients. Thus, this guideline does not apply to a small-scale server room equipped with only a few pieces of ICT equipment.

6.3 Figure of Merit on Energy-Saving As a Normative Reference

(1) Figure of merit on energy-saving that may be used now

One figure of merit on energy-saving for data centers that may be used now is the Power Usage Effectiveness (PUE) figure of merit, which compares the power consumption of the ICT equipment that should be in operation to the power consumption of the facility portion (air-conditioning, power source, lighting, etc.) used to operate the ICT equipment. PUE is a figure of merit proposed by The Green Grid (US) and its definition is as follows.

$$\text{PUE} = \text{power consumption of entire facility (ICT equipment + facilities)} / \text{power consumption of ICT equipment}$$

Based on this definition, one could say that a small PUE value could mean that the facilities portion of a data center has good energy efficiency.

PUE is the figures of merit on energy-saving for data centers most widely adopted so far.

At the same time, there are those who point to issues with PUE . One is that the measurement methods are not always clearly defined. Another is that the metrics do not consider differences in energy efficiency derived from efficiency of the ICT equipment and operational proficiency.

(2) The status of studies at related organizations

Japan's Green IT Committee in JEITA has worked on the development of an independent figure of merit on energy-saving covering the entire data center including ICT equipment. The Committee has proposed its DPPE (Datacenter Performance Per Energy) as a figure of merit on energy-saving covering the entire data center. The DPPE is consisted of a function of 4 sub-figures of merit, which are as follows.

Sub-figure of merit	Formula	Measures covered
ITEU (IT Equipment Utilization)	= Datacenter's usage rate of IT equipment	Effective use of IT equipment
ITEE (IT Equipment Energy Efficiency)	= Total rated capacity of IT equipment/ Total rated power consumption of IT equipment	Installation of energy conserving IT equipment
PUE (Power Usage Effectiveness)	= Total power consumption of the datacenter/ Energy consumption of IT equipment	Reduction in power consumption by the facility
REF (Renewable Energy Factor)	= Renewable energy electricity/ Total power consumption of the datacenter	Use of Renewable electricity

(Source: Green IT Promotion Council "Concept of New Metrics for Data Center Energy Efficiency Introduction of Datacenter Performance per Energy (DPPE)" Feb., 2010)

The Green IT committee has been promoting activities for global standardization of sub-figure of merits with JTC 1 / SC 39 (Sustainability for and by IT) established under the collaboration of the ISO and IEC. As a result, in 2016, PUE and REF and

published as ISO / IEC 30134-2, ISO / IEC 30134-3, in 2017 ITEE and ITEU and published as ISO / IEC 30134-4, ISO / IEC 30134-5, It was officially issued as a global standard. Currently, only four figure of merit on energy-saving of data centers, which are global standards, are available.

As these figures of merit become global standards, they will be used in government procurement in each country in the future. Furthermore, in Europe as a whole, we are planning to incorporate these figures of merit that have become these global standards in the revision work of the European Data Center Standard (EN 50600).

Moreover, under the EU's Code of Conduct on Data Centers, a guideline compiled for data centers, PUE is adopted as a figure of merit on energy-savings for facilities, while a productivity figure of merit is to be decided in consideration of future trends. Furthermore, the US Environmental Protection Agency (USEPA) uses PUE to rate the energy efficiency of facilities, and issues EnergyStar certification to energy efficient Data Centers.

On the other hand, organizations such as ISO/IEC and ITU-T are also continuing to look into figures of merit for datacenter environment and/or energy efficiency. This Council will monitor progress of these efforts and when deemed necessary, consider reflecting their output in this Guideline.

(3) Data Center Figure of Merit on Energy-Saving under this Guideline

In light of current studies on figures of merit on energy-saving and the situation of global adoption, this Guideline preliminarily uses PUE, already adopted as a figure of merit on energy-saving for the facilities portion, which serves as a useful reference for data centers to perform CO₂ emission reduction activities and for telecommunications service providers to procure data center services. It is preferred that data center operators measure energy conservation related data (e.g. PUE with clear measurement conditions) and advance public disclosure. This guideline will continue to revisit figures of merit in consideration of future trends in studies on the issues inside and outside of Japan.

6.4 Outline of Figure of Merit on Energy-Saving

(1) PUE

PUE, currently an important figure of merit on energy-saving for data centers, is as described in 6.3(2), and published as IOS/IEC 30124-2 2016.

Here, ICT equipment includes computers, network equipment, ICT support systems (printers, etc.), storage, and telecommunications equipment. Facilities refer to equipment not included under ICT equipment, namely, electrical power (converters, UPS, lighting, etc.), air conditioning (including cooling tower, cooling water pump, humidifier, etc.), security equipment, building management systems and the like. In the case that a data center uses other energy sources in parallel to electrical power, use an energy conversion value to calculate PUE. Specifically, use

a crude oil equivalent value for the amount of energy consumed as defined by the Energy Conservation Law.

(2) Measurement Methods for PUE

PUE measurement methods (measurement frequency, selecting measurement points, etc.) are published as IOS/IEC 30134-2 2016.

(3) Disclosure Items and Methodology of Data Center Energy-Efficiency Data

The energy efficiency of data centers is believed to differ depending on the characteristics of the data center. Thus, in disclosing energy-efficiency data, the basic characteristics of a data center that would significantly impact energy efficiency need also be disclosed. As an attempt at tentative uniformity in consideration of user convenience, specific disclosure items should include, in addition to the actual PUE measurement values, measurement methodology, data center location, room temperature and humidity settings, duration of measurement, and redundancy configurations.

This guideline will not stipulate uniform measurement methods, but the data center address, internal thermostat/humidity settings and redundancy configuration should be disclosed.

Disclosure items for data center energy efficiency

Disclosure items		Example of information entry
Name of operator		XYZ Co., Ltd.
Name of data center		Tokyo Data Center
Energy efficiency measures		Cold aisle capping
Basic features	Data center location	Country, area (larger Tokyo metro area)
	Internal temperature/humidity setting	22°C/50 - 60%
	Redundancy configuration	N+1

7. Assessment Standard Eco ICT Logo

7.1 Purpose

7.1.1 Purpose of Self-Assessment of Efforts

The status of efforts and achievements in reducing CO₂ emissions through energy conservation made by telecommunications service providers needs to be publicly disclosed (made visible) in an appropriate and timely fashion so that external parties

including users and other related parties may appropriately assess such efforts.

In light of such needs, the purpose of these endeavors is to encourage telecommunications services providers to check the status of those efforts under their own initiative and to enhance their efforts to be ecologically conscious and to reduce their burden on the environment.

7.1.2 Indication of Eco ICT Logo

Telecommunications services providers shall display the “Eco ICT Logo” as a medium for broad public disclosure depending on the result of appropriate self-assessment of their through energy conservation activities to reduce CO₂ emissions etc. and to indicate the status of such implemented actions.

The following entities may display the “Eco ICT Logo:”

- > Telecommunications services providers.
- > A person who operates a telecommunications business defined under the Telecommunications Business Act, other than Telecommunications services providers.
- > Neither of the above, but operating business related to telecommunications services using substantial ICT equipment AND recognized by the Council.

7.2 Checklist

7.2.1 Purpose of the Checklist

The Council has prepared the Self-Assessment Checklist for CO₂ Emission Reduction Efforts Through Energy Conservation by Telecommunications Services Providers (hereinafter, the Checklist) (see separate sheet) for telecommunications services providers to set targets for reducing CO₂ emissions through energy conservation and to use the checklist for self-confirmation and make their efforts visible to others.

The purpose is for telecommunications services providers to use this checklist to perform self-assessments of the results of actions plans prepared and implemented by individual companies and as a medium for public disclosure.

7.2.2 Checklist Assessment Items and Assessment Standards

<Preparation of a Voluntary Ecological Action Plan>

- [1] Has a voluntary ecological action plan stipulating various efforts directed at reducing CO₂ emissions through energy conservation been created and is it being executed?

- Is there a voluntary ecological action plan in place, which is aimed at promoting ecological preservation activities such as the prevention of global warming, reduction of waste and the promotion of reduce, reuse and recycling activities?

[2] Does the ecological policy include specific efforts stipulating numerical targets for the reduction of CO₂ emissions through energy conservation?

- Does the voluntary ecological action plan include specific activities and numerical targets?

Examples

- Reduce by the end of 2020 the amount of electricity used by ICT equipment by 25%, compared to 1990 levels.
- Switch to green power generation, purchase green power certificates and the like, so that green power accounts for 10% of electricity used.
- 10% reduction on a year-to-year base employees' use of private vehicles for commuting by promoting the use of public transportation, bicycles and car-sharing.

[3] Is the ecological policy documented and disseminated inside and outside the company? Does the company carry out activities to inform and enlighten its employees? Is the company working to raise ecological awareness?

- Are employees informed of such plans through internal training events and the like?
- Is information disclosed outside the company or is information disclosed to interested parties and other members of the general public when needed?

[4] Does the company disclose to the general public its activities and data such as CO₂ emission reduction?

- Is such information as progress reports, accomplishments and track record of specific activities under the voluntary ecological action plan disclosed to the public?
- Does that information continue to be publicly disclosed based on annual reviews?

*May be substituted with the creation and disclosure of an ecological report, CSR report, sustainability report, and the like.

Examples

- URL of the company's website where the status of specific actions taken in accordance with the voluntary ecological action plan is disclosed
- URL of the company's blog where information on ecological activities is disseminated on a continual basis

<Efforts Related to Procurement>

[5] In regard to ICT equipment and data center services, has the company

prepared a procurement standard based on assessment standards specified in this Guideline? Is procurement carried out in accordance with the standard?

- Is there a procurement standard prepared in reference to this Guideline that relates to ICT equipment and data center functions the company plans to procure?
- Are ICT equipment and data centers with advanced energy conservation features being procured in accordance with an established procurement standard?

[6] Is the company cognizant of energy conservation in procuring office equipment, supplies and logistics (e.g., green purchasing)?

- Is the company implementing green purchasing?
- Are specific procurement measures taken in consideration of energy conservation?

Examples

- Introducing fluorescent lamps and office equipment with low power consumption.
- Prioritize procuring products and services minimizing burden on the environment from providers who make an effort to lower negative environmental impact.

<Promotion Regime>

[7] In relation to efforts to reduce CO₂ emissions through energy conservation, has the company assigned a person or department to be responsible for such matters?

- Has the company assigned a person or department to be responsible for promoting these efforts, regardless of whether those resources are dedicated or hold other concurrent responsibilities?

[8] Is there a regime in place using internal audits or other means to keep appropriate track of the implementation of measures and achievement of targets set forth in the voluntary ecological action plan? Is the internal audit performed by a department other than the department that sets targets?

- Are member companies of industry groups auditing each other?
- Or does the company receive external audits or comments from third parties?

Examples

- Member companies of industry groups audit each other.

<Other Ecological Activities>

[9] Are ecologically-friendly efforts being made other than activities to save energy?

- Is the company involved in resource conservation in the office by conducting double-sided printing or printing on the flip side of already printed paper and trying to reduce waste? If so, specific activities shall be indicated.

Examples

- Working to use double-sided printing and copying, reduce the amount of paper and ink used, and reduce the amount of power used for printing.
- Working to decrease the number of pages printed by not printing out unnecessary pages.

[10] Is the company involved in ecological preservation activities in collaboration with local communities?

- Does the company work on a continual basis with society on activities related to ecological preservation?

Examples

- Work jointly with regional organizations every month to pick up garbage and increase plant coverage in local areas.
- Participate in community recycling activities to actively recycle.
- Participate in eco-cap activities and make contributions to society beyond recycling efforts.

7.2.3 Review of the Checklist

The Council shall review this checklist and its items as appropriate in response to: reviews of this Guideline; changes in policy relating to global warming measures; revisions to laws and ordinances; the status of ICT service provision; penetration of equipment and the like; and technological advances.

7.3. Eco ICT Logo

7.3.1 Method of Indication

In accordance with 7.3.2, telecommunications services providers may use on their website and printed matter the name of the logo and the “Eco ICT Logo” set forth in the reference section of the Guideline.

7.3.2 Usage Stipulations

(1) Usage Standard

In using the name and “Eco ICT Logo,” disclosure by the means set forth in 7.4.2 must be followed.

(2) How to Obtain

The “Eco ICT Logo” may be downloaded in electronic format from the Council's website.

(3) The permissible scope of use of the name and “Eco ICT Logo” by a telecommunications services provider

- The company's website
- The company's advertisements requested to be posted on a third party's website
- E-mails sent by the company or by a third party at the request of the company
- Business cards
- Materials distributed in an electronic format
- Printed pamphlets, distribution materials, leaflets, mailings, etc.
- Projection data used in presentations

(4) Reminders in Use of Logo

When using the name and “Eco ICT Logo,” telecommunications services providers shall do so under the following conditions.

- [1] Expenses shall be borne by the telecommunications service provider.
- [2] The name and “Eco ICT Logo” must be used in their entirety, without changing the aspect ratio or the color of the “Eco ICT Logo.”
- [3] When use of the name or the “Eco ICT Logo” by a telecommunications services provider might possibly conflict with the intent of self-assessment efforts to reduce CO₂ emissions through energy conservation or conflict with public order or standards of decency, or otherwise, the Council may advise the telecommunications services provider of correction based on a judgment by the Council.

(5) Discontinuing Use of the Logo

- [1] In the event a telecommunications services provider using the name or “Eco ICT Logo” fails to perform self-assessment of efforts to reduce CO₂ emissions through energy conservation, the telecommunications services provider must promptly discontinue use of the name and “Eco ICT Logo.”
- [2] In the event a telecommunications services provider does not comply with the stipulations under 7.3.2 and rules regarding usage separately set forth by the Council, the Council may remove the company from the Council's website and notify of the discontinuation of use of the name and “Eco ICT Logo.”

7.4. Implementation

7.4.1 Assessment Methods

- [1] The telecommunications services provider shall perform self-assessment based on the checklist as to whether the company is actively implementing efforts to reduce CO₂ emissions through energy conservation.
- [2] If the telecommunications services provider is judged to be appropriately implementing efforts indicated in the checklist, the telecommunications services provider shall be responsible for describing an overview of specific efforts being implemented in the checklist.
- [3] Items 1 to 8 on the checklist are mandatory entries (must describe the company's efforts) and items 9 and 10 are recommended (free to list information in checklist or not).
- [4] In the event certification of an international standard (ISO 14001) relating to environmental management systems has been acquired, companies may substitute check list entries as appropriate with an indication that certification has been acquired under the applicable assessment items and a description of where that information is made be publicly available.

7.4.2 Public Disclosure Methods by Telecommunications Services Providers Conducting the Efforts

The following information of telecommunications services providers involved in efforts complying with the checklist shall be publicly available through the Council's website.

- Company name (personal name or trade name if an individual)
- URL and link to where the checklist is posted

Telecommunications services providers need to disclose the completed checklist and provide sufficient information for a user or viewer to understand what sort of efforts was made that apply to or comply with the checklist per the self-assessment.

(1) Submitting Necessary Forms & Information

- [1] Telecommunications services providers shall post the checklist prepared per 7.4.1(2) on their website and make a submission to the Council via the Council website.
- [2] If a telecommunications services provider having information disclosed on the Council's website needs to revise targets aimed at reducing CO₂ emissions through energy conservation or change specific effort within the effective period of disclosure, the telecommunications services provider shall follow the procedures similar to those for the original Application as

deemed appropriate via the Council website.

(2) Effective Period of Disclosure by the Council

- [1] Regarding results of telecommunications services providers' specific efforts toward targets aimed at appropriately reducing CO₂ emissions through energy conservation, such targets need to be reviewed at least once a year, since continuity and improvement contributes greatly to reducing CO₂ emissions. Thus, the effective period of disclosure by the Council shall be no longer than one year and continue to the last day of December of each year.
- [2] When self-assessment of efforts to reduce CO₂ emissions through energy conservation is performed, a checklist is completed and submitted at some point between January 1 and the last day of December. The effective period of disclosure by the Council shall continue until the last day of December of the year disclosure began and shall not be calculated as one full year from the date of disclosure.

(3) Method of Renewing Public Disclosure by the Council

- [1] Telecommunications services providers shall submit necessary information to the Council between October 1 and the last day of December of each year, receive confirmation for renewal and have disclosure by the Council renewed.
- [2] For renewal, a telecommunications services provider submits procedures similar to those for the original report to the Council via the Council website.
- [3] If a telecommunications services provider does not report for renewal by the last day of December each year, the Council may remove that company from the list and cancel the company's usage of the name and "Eco ICT Logo."
- [4] Telecommunications services providers removed from the list disclosed by the Council must promptly discontinue use of the name and "Eco ICT Logo" on their own websites and printed matters.

(4) Others

- [1] If a third party inquires about the disclosed contents regarding a telecommunications services provider on the Council's website, the inquiry may be routed to the relevant telecommunications services provider.
- [2] The telecommunications services provider subject to the inquiry must answer and respond in good faith.

<Diagram of Logo for Reference>

Eco ITC Logo design



Attachment 1

Self-Assessment Checklist for CO₂ Emission Reduction from Energy Conservation Efforts by Telecommunications Services Provider

Telecommunications services provider: _____

<Mandatory items>

		Assessment items	Implementation, measures taken
Preparation of a voluntary ecological action plan	1	Has a voluntary ecological action plan stipulating various efforts directed at reducing CO ₂ emissions through energy conservation been created and is it being executed?	
	2	Does the ecological policy include specific efforts stipulating numerical targets for the reduction of CO ₂ emissions through energy conservation?	
	3	Is the ecological policy documented and disseminated inside and outside of the company? Does the company carry out activities to inform and enlighten its employees? Is the company working to raise ecological awareness?	
	4	Does the company disclose to the general public its activities and data such as CO ₂ emission reduction?	
Efforts relating to procurement	5	In regard to ICT equipment and data center services, has the company prepared a procurement standard based on assessment standards specified in this Guideline? Is procurement carried out in accordance with the standard?	
	6	Is the company cognizant of energy conservation in procuring office equipment, supplies and logistics (e.g., green purchasing)?	
Promotion regime	7	In relation to efforts to reduce CO ₂ emissions through energy conservation, has the company assigned a person or department to be responsible for such matters?	
	8	Is there a regime in place using internal audits or other means to keep appropriate track of the implementation of measures and achievement of targets set forth in the voluntary ecological action plan?	

<Recommended items>

Other ecological	9	Are ecologically-friendly efforts being made other than activities to save energy?	
------------------	---	--	--

activities	10	Is the company involved in ecological preservation activities in collaboration with local communities?	
------------	----	--	--

(TCA202302xxV00R01)